

Řízení, regulátor tahu, skluzová ochrana
Lo 11 203 P

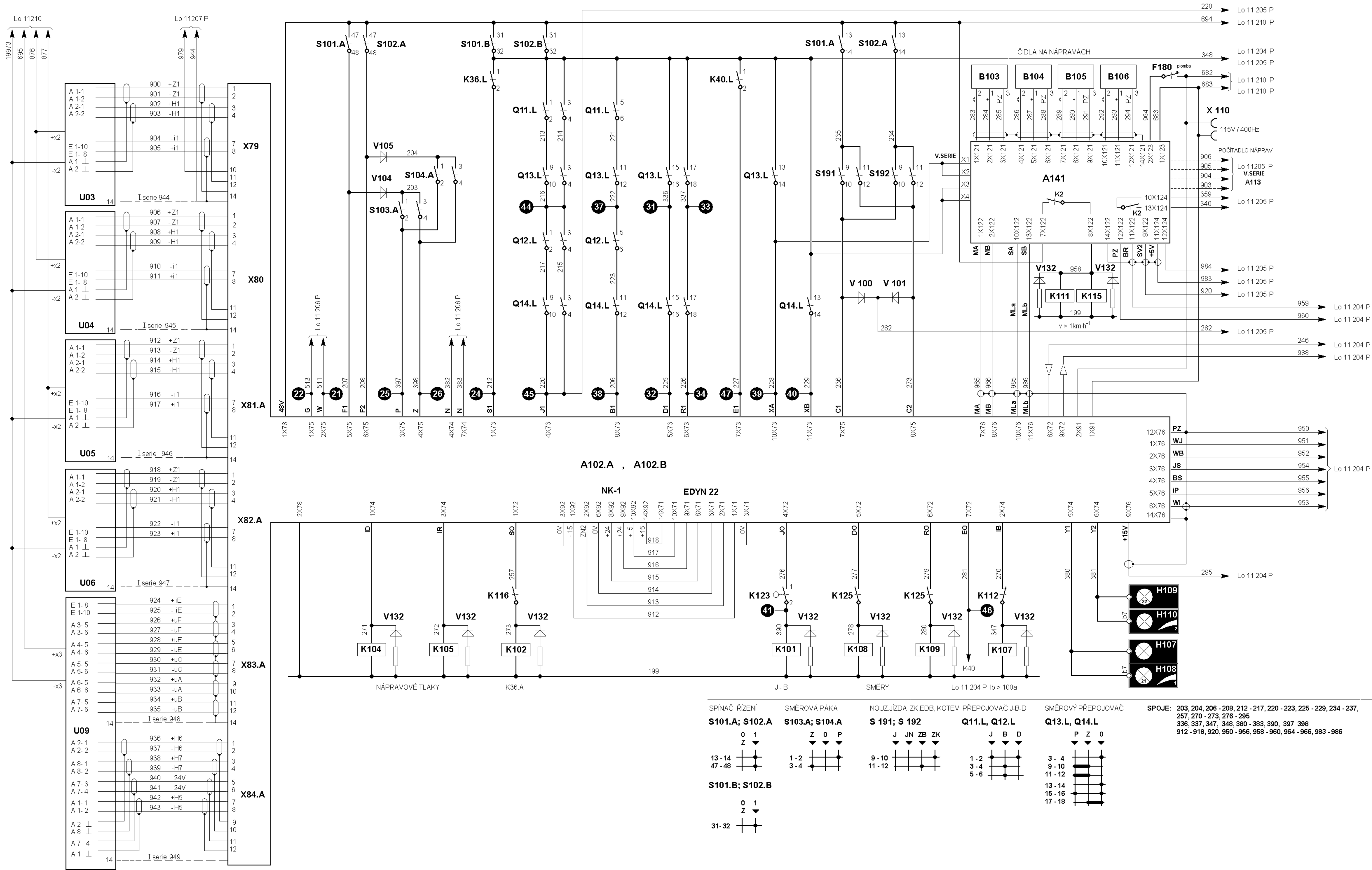

SPÍNAČ ŘÍZENÍ	SMĚROVÁ PÁKA	NOUZ.JÍZDA, ZK EDB, KOTEV	PRÉPOJVAČ J-B-D	SMĚROVÝ PRÉPOJVAČ	SPOJE:
S101.A; S102.A 0 1 Z ↓ 13-14 47-48	S103.A; S104.A Z 0 P 1-2 3-4	S 191; S 192 J JN ZB ZK 9-10 11-12	Q11.L, Q12.L J B D 1-2 3-4 5-6	Q13.L, Q14.L P Z 0 3-4 9-10 11-12 13-14 15-16 17-18	203, 204, 206 - 208, 212 - 217, 220 - 223, 225 - 229, 234 - 237, 267, 270 - 273, 276 - 295, 336, 337, 347, 348, 380 - 383, 390, 397 398, 912 - 918, 920, 950 - 956, 958 - 960, 964 - 966, 983 - 986
S101.B; S102.B 0 1 Z ↓ 31-32					

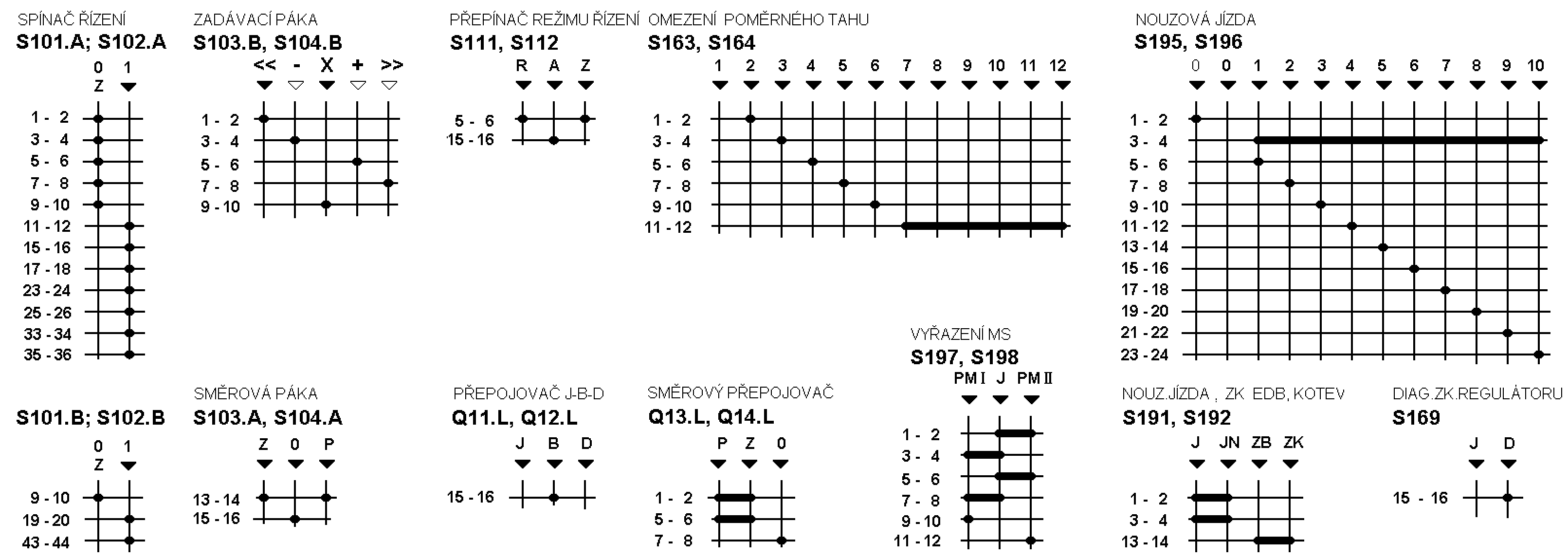
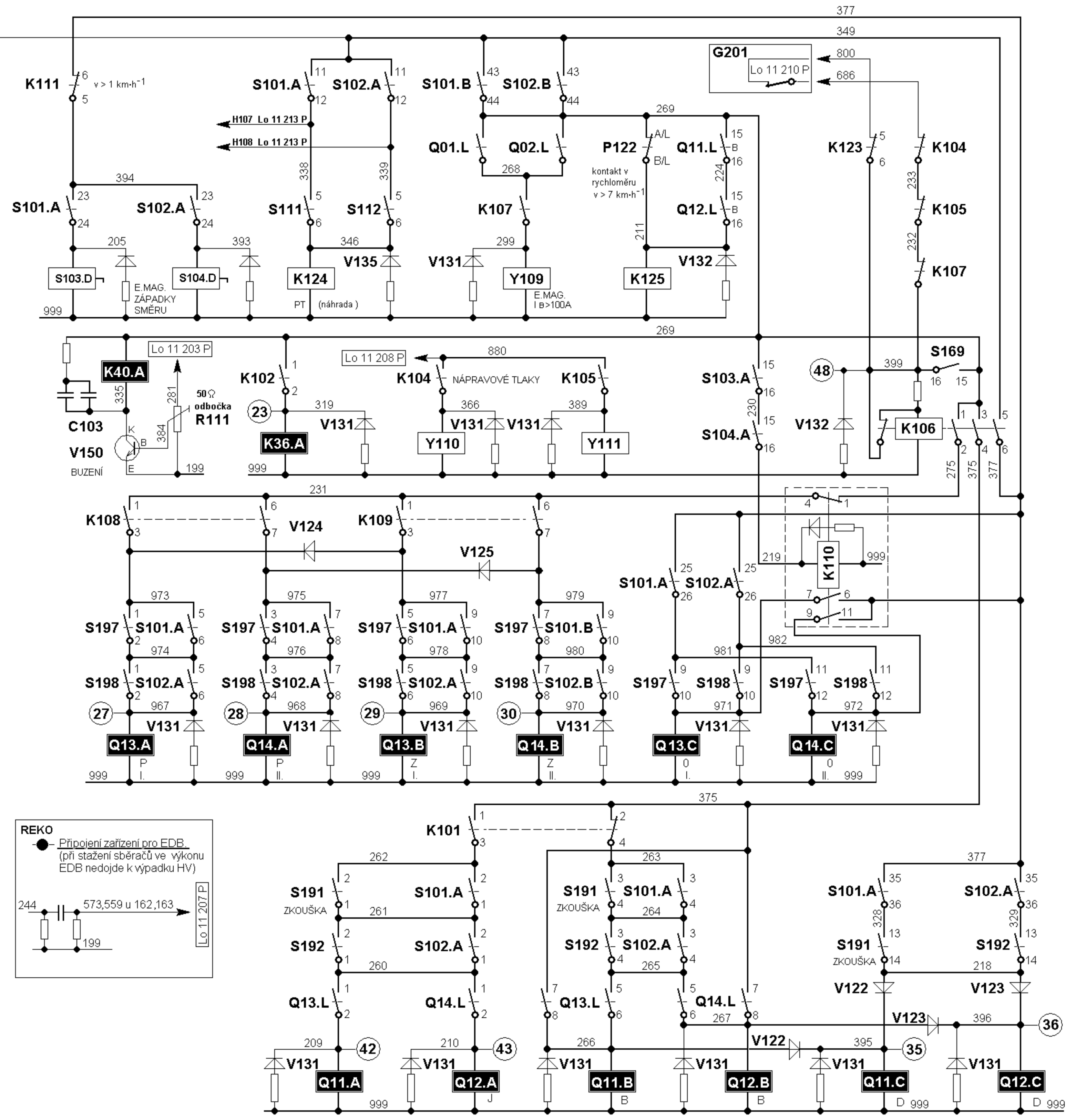
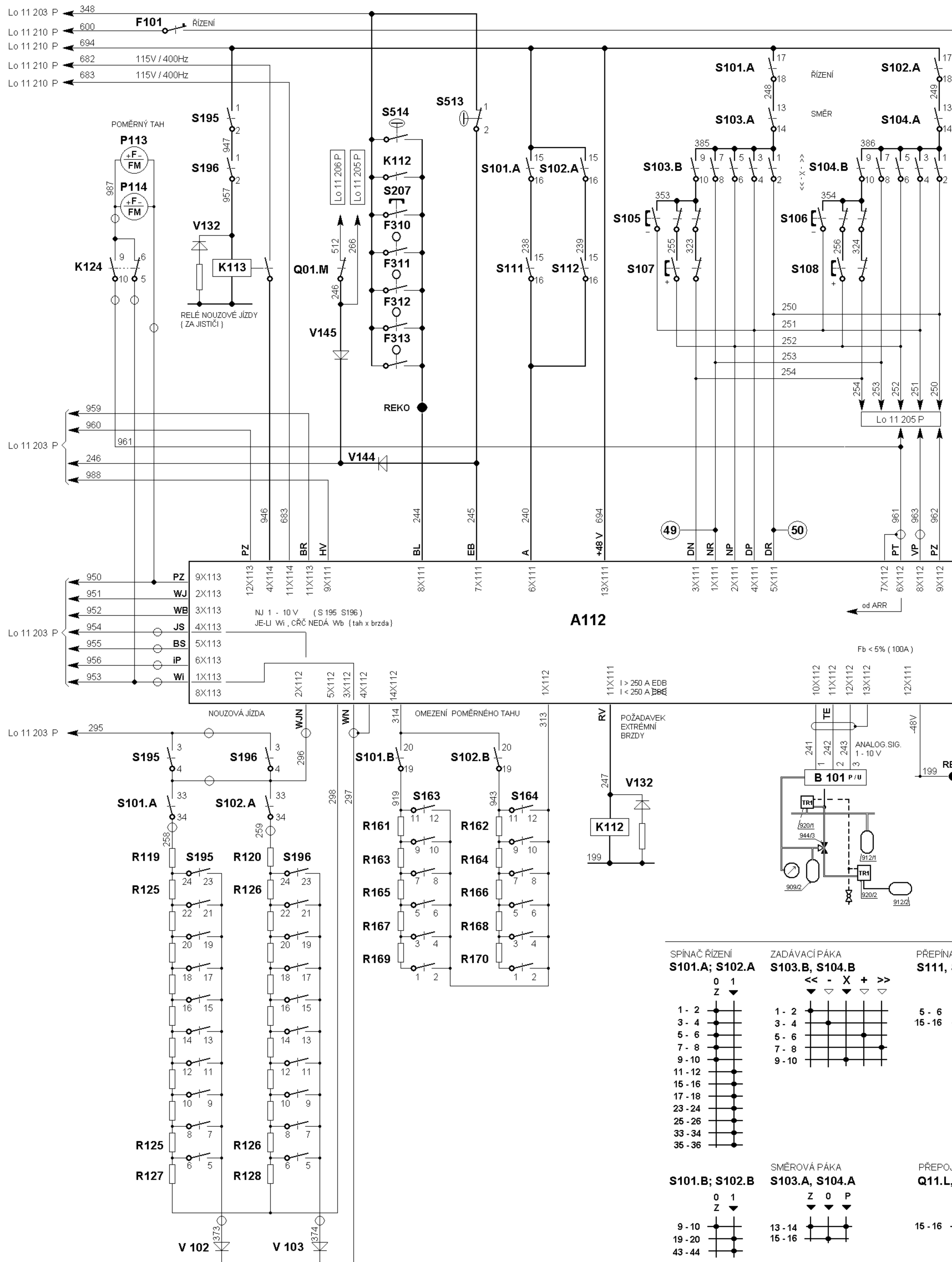

SPOJE: 205, 209 - 211, 218, 219, 224, 230 - 23X
 238 - 249, 261 - 266, 268 - 268, 275,
 296 - 299, 313, 314, 319, 323, 349,
 328, 329, 335, 338, 339, 345, 353,
 354, 366, 373 - 375, 377, 385 - 386,
 389, 393 - 396, 399,
 919, 940, 941, 943, 946 - 947, 957,
 963, 967 - 982, 987, 988

Řízení, centrální řídicí člen Lo 11 204 P

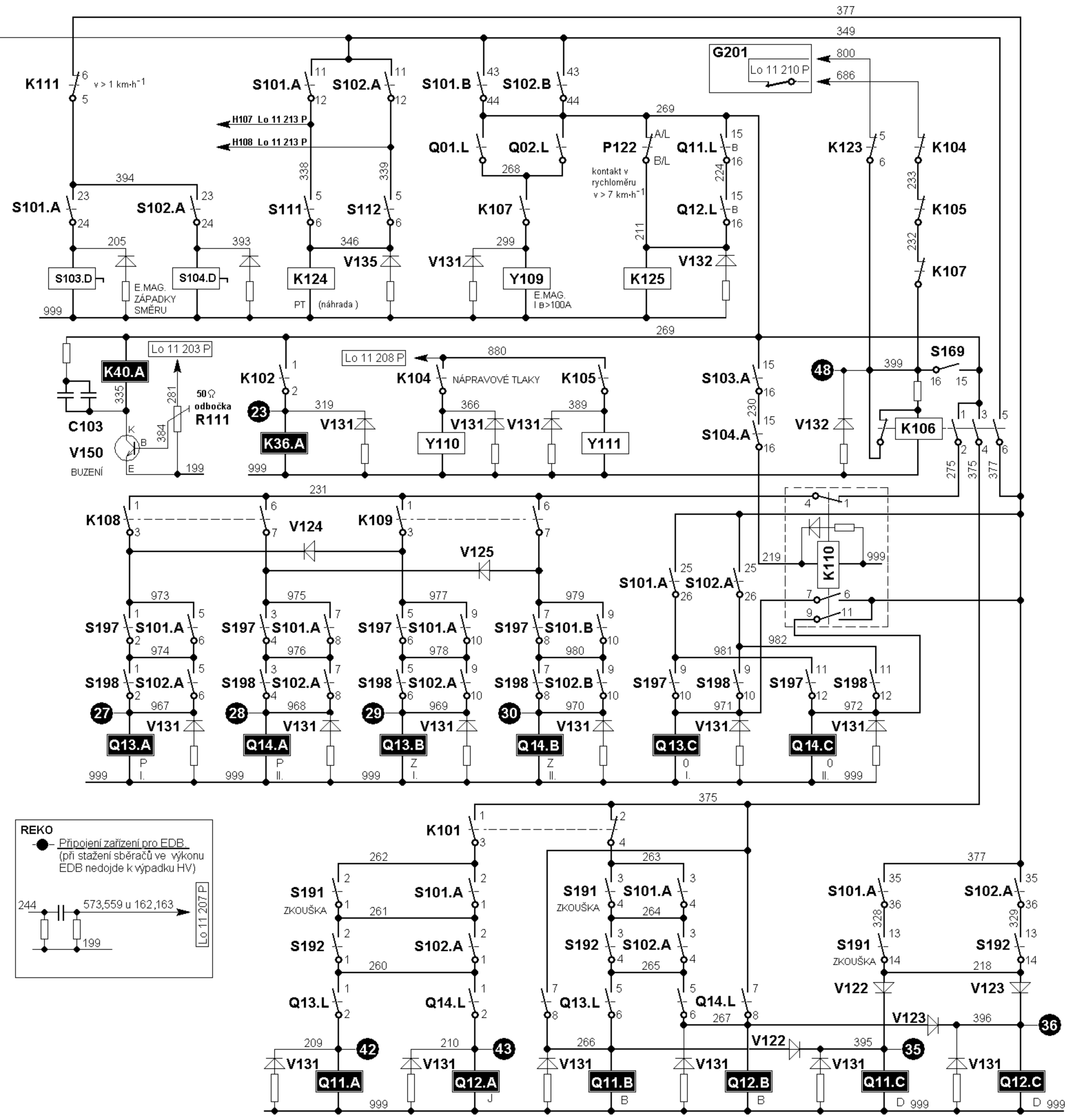
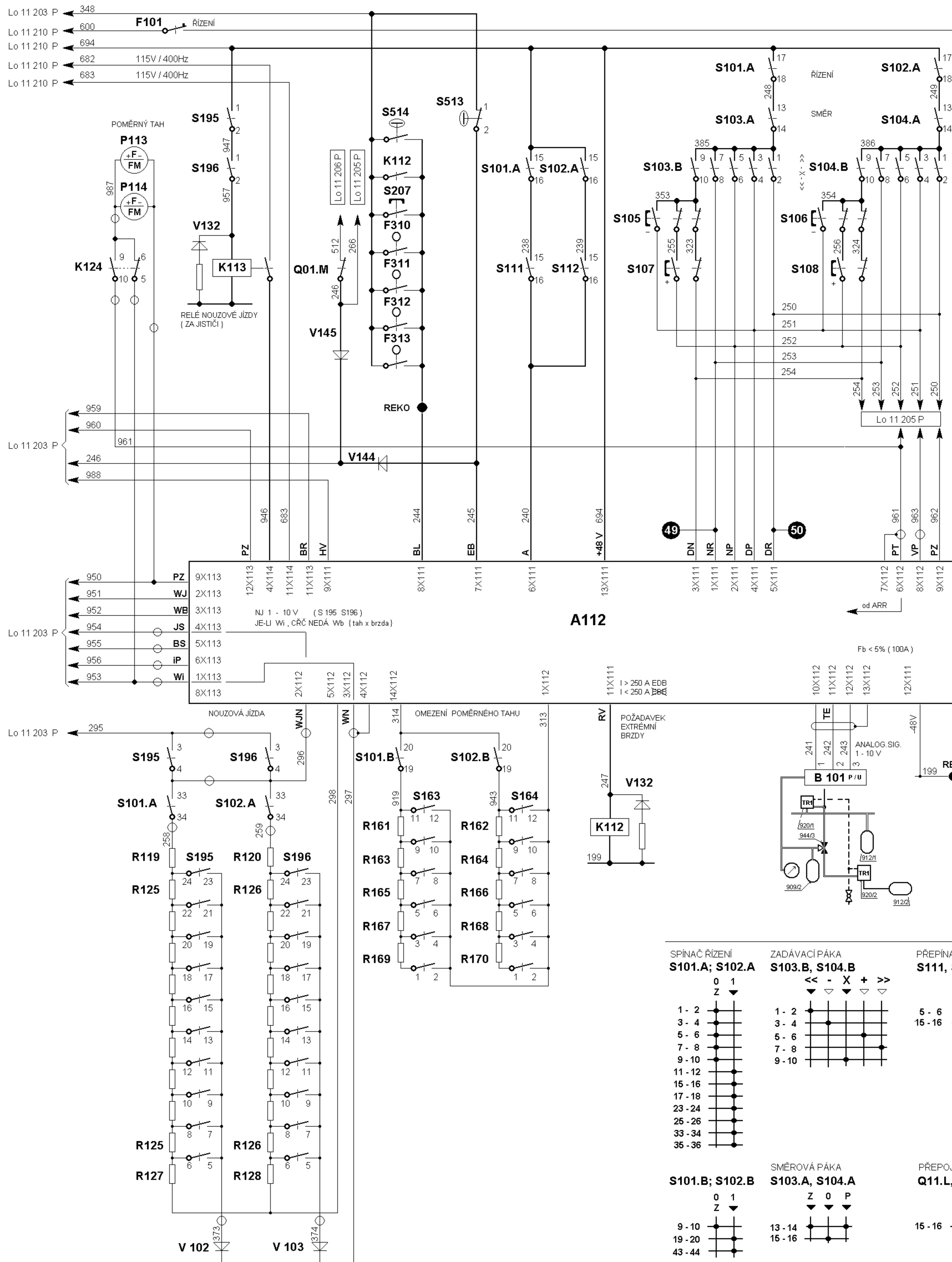

SPINAČ ŘÍZENÍ

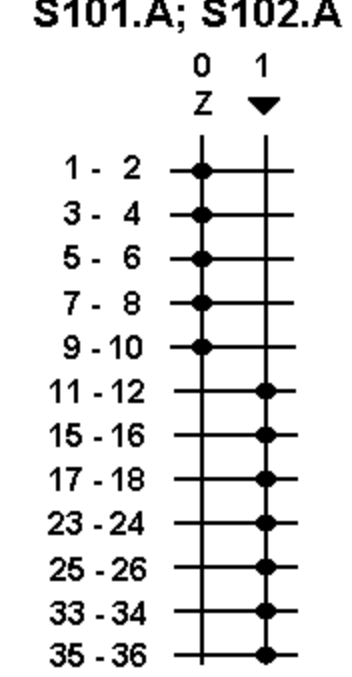

ZADÁVACÍ PÁKA

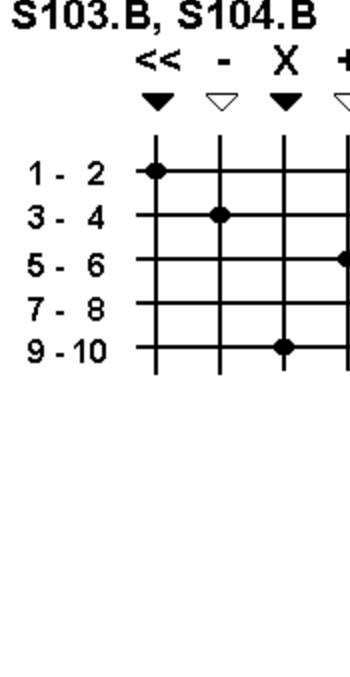

PŘEPÍNAČ REŽIMU ŘÍZENÍ

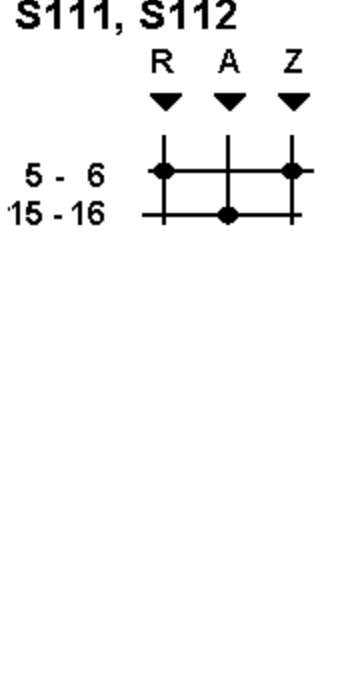

OMEZENÍ POMĚRNÉHO TAHU

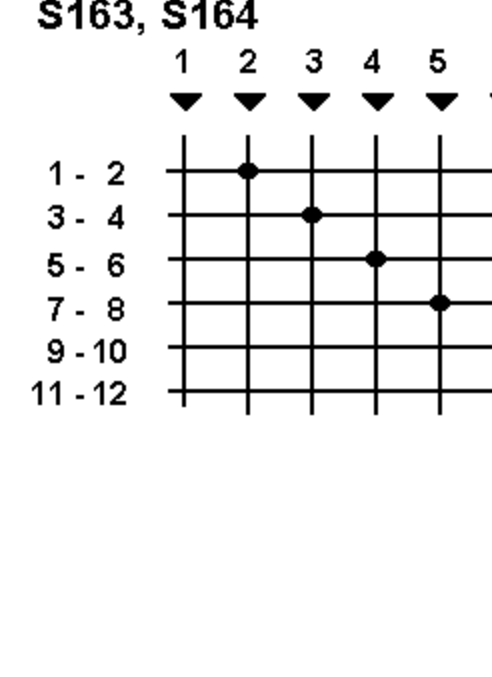

NOUZOVÁ JÍZDA

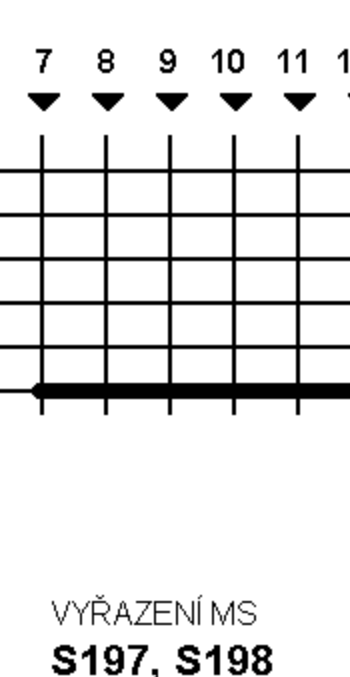

S101.B; S102.B

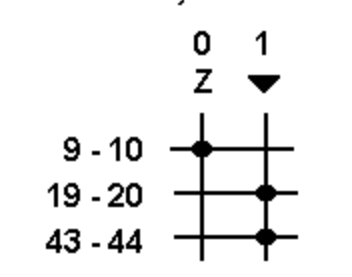

SMĚROVÁ PÁKA

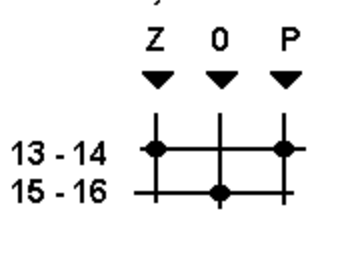

PŘEPOJOVAČ J-B-D

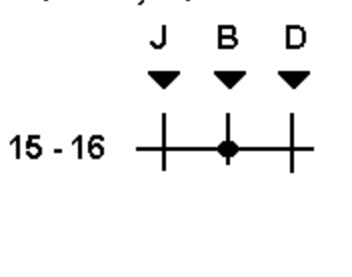

SMĚROVÝ PŘEPOJOVAČ

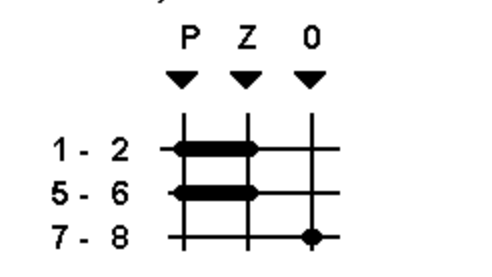

VYŘAZENÍ MS

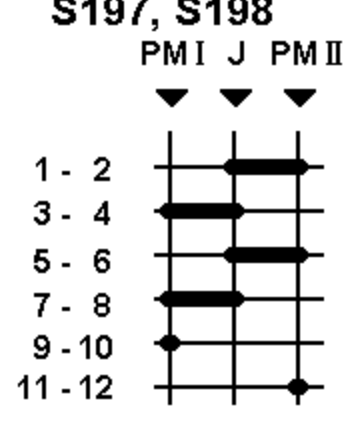

NOUZOVÁ JÍZDA

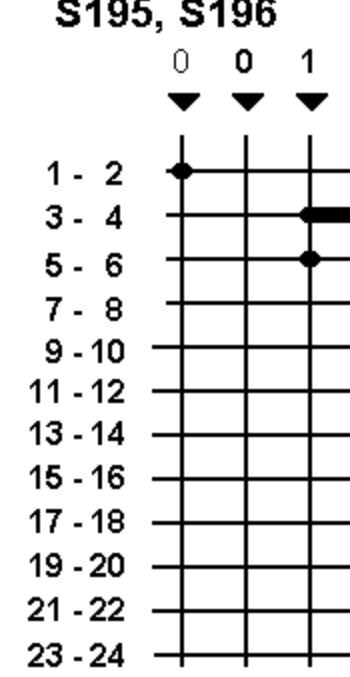

NOUZOVÁ JÍZDA, ZK EDB, KOTEV

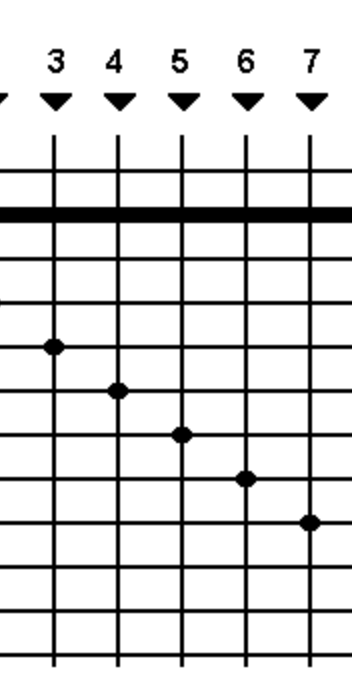

DIAG. ZK. REGULÁTORU

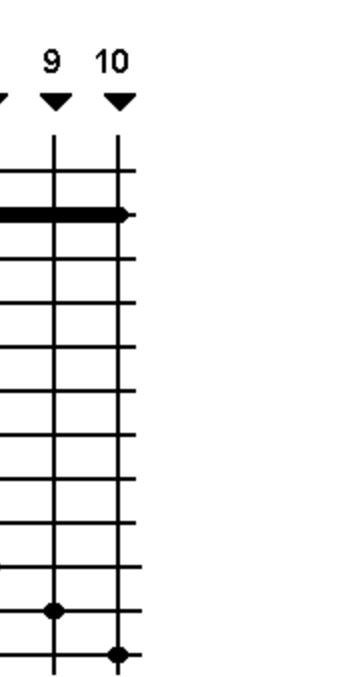

SPOJE: 205, 209 - 211, 218, 219, 224, 230 - 23X
238 - 249, 261 - 266, 268 - 268, 275,
296 - 299, 313, 314, 319, 323, 349,
328, 329, 335, 338, 339, 345, 353,
354, 366, 373 - 375, 377, 385 - 386,
389, 393 - 396, 399,
919, 940, 941, 943, 946 - 947, 957,
963, 967 - 982, 987, 988

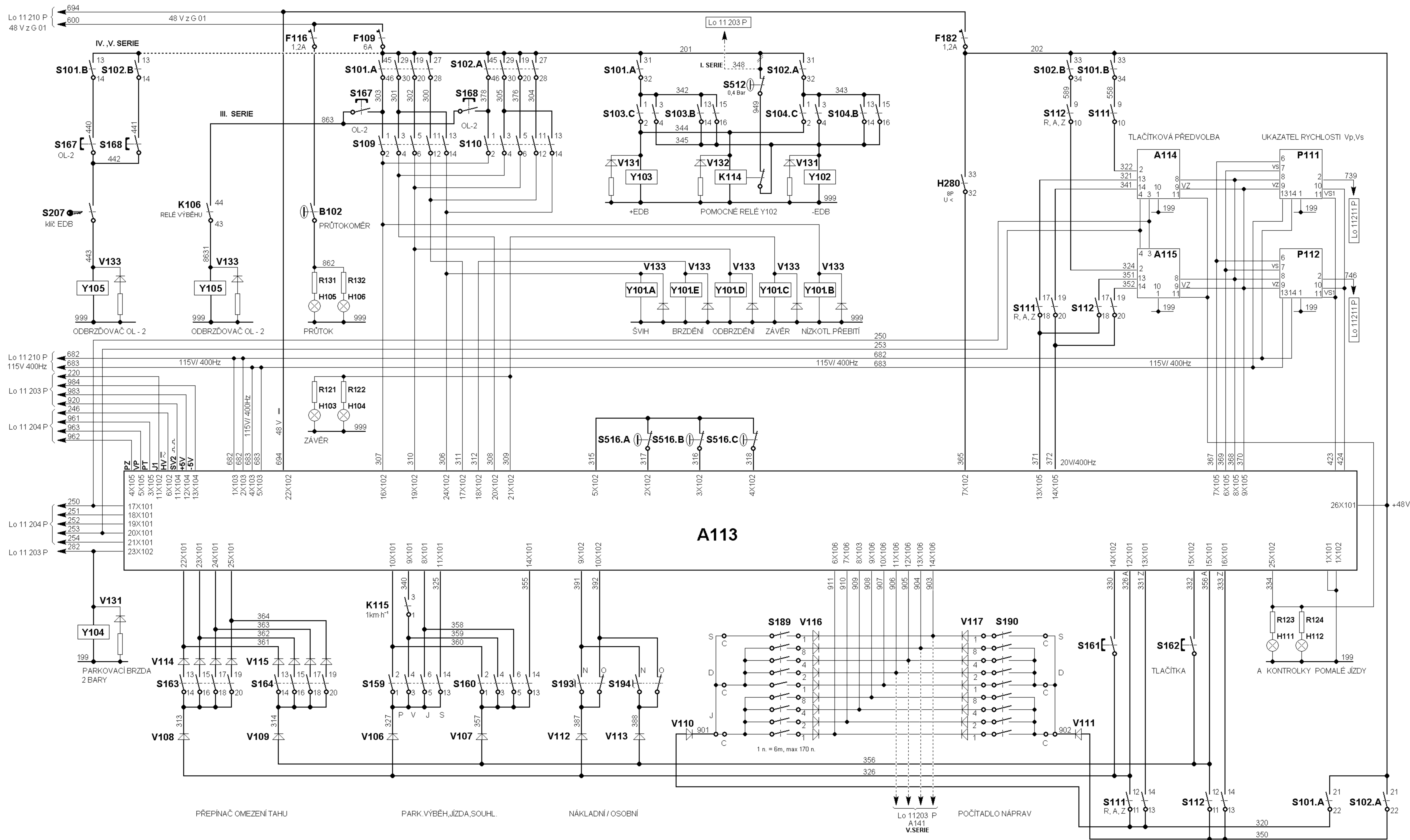

A113

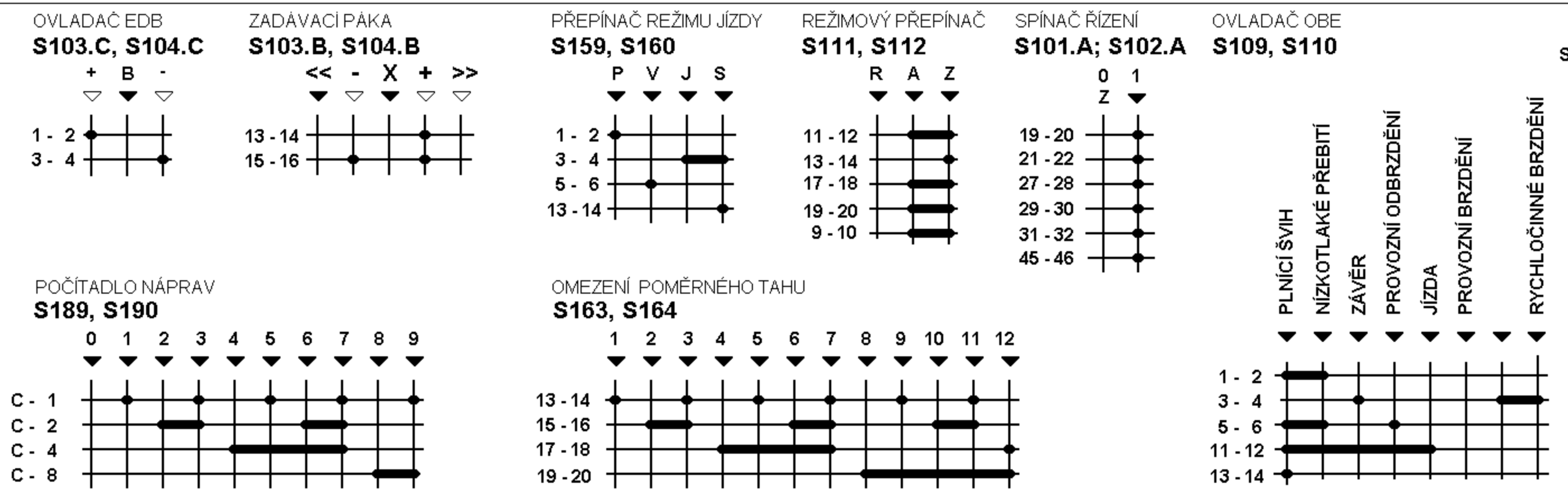

SPOJE: 201, 202, 300 - 312, 315 - 318, 320, 321, 325 - 327, 340 - 345, 355 - 365, 367 - 372, 376, 378, 387, 388, 391, 392, 901 - 911, 944, 945, 961, 962, 949

Řízení, regulátor rychlosti a elektropneumatická brzda Lo 11 205 P

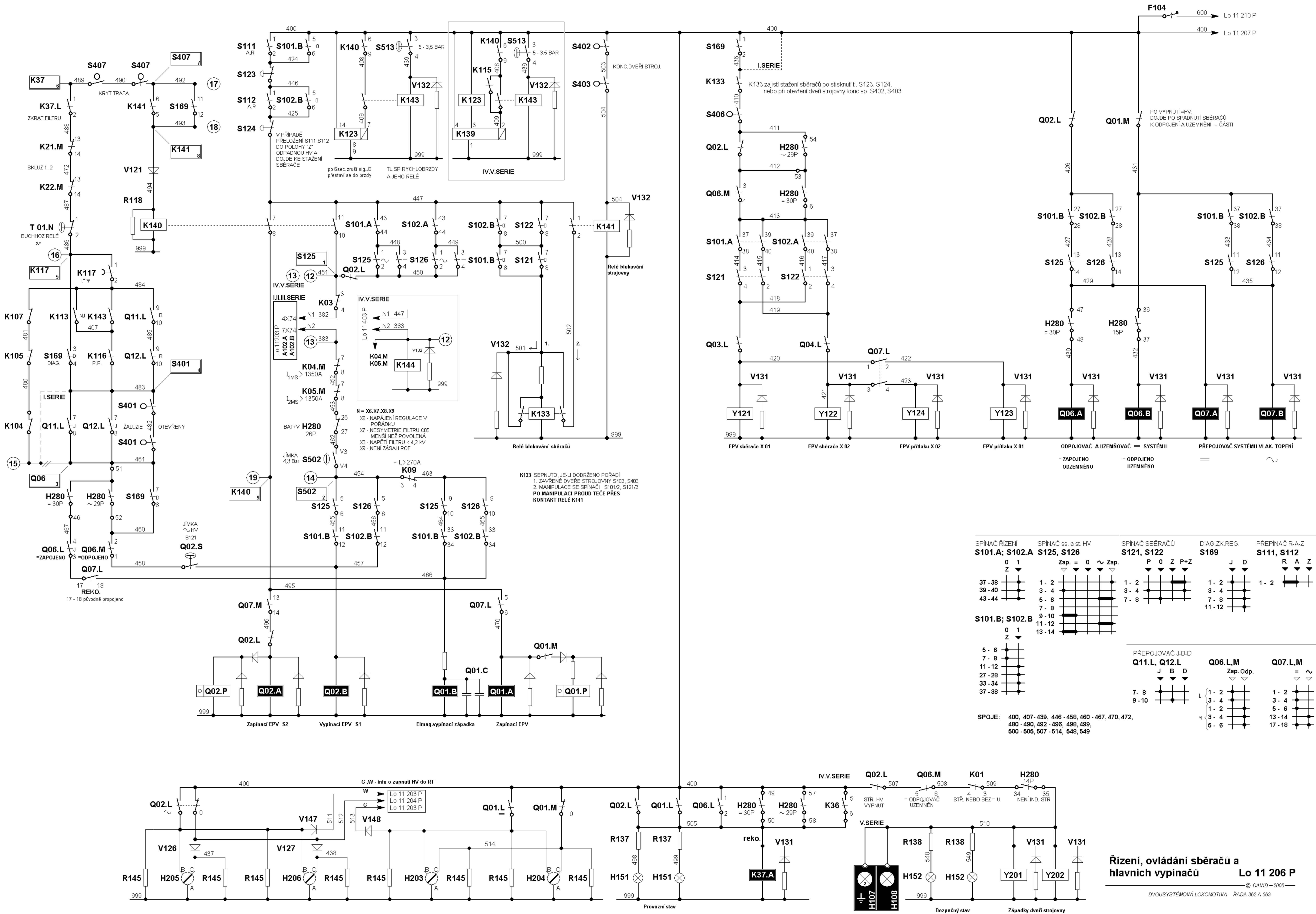

Rízení, ovládání sběračů a hlavních vypínačů
Lo 11 206 P

SPINAČ RÍZENÍ	SPINAČ ss. a st. HV	SPINAČ SBĚRAČŮ	DIAG. ZK. REG.	PŘEPÍNAČ R-A-Z
S101.A; S102.A	S125, S126	S121, S122	S169	S111, S112
0 1 Z	Zap. = 0 ~ Zap.	P 0 Z P+Z	J D	R A Z
37 - 38 39 - 40 43 - 44	1 - 2 3 - 4 5 - 6 7 - 8 9 - 10 11 - 12	1 - 2 3 - 4 7 - 8	1 - 2 3 - 4 7 - 8 11 - 12	1 - 2
S101.B; S102.B				
0 1 Z				
5 - 6 7 - 8 11 - 12 27 - 28 33 - 34 37 - 38				
SPOJĚ: 400, 407, 439, 446, 458, 460, 467, 470, 472, 480, 490, 492, 496, 498, 499, 500, 505, 507, 514, 548, 549				

PŘEPOJOVAČ J-B-D

Q11.L, Q12.L	Q06.L,M	Q07.L,M
J B D	Zap. Odp.	= ~
7 - 8 11 - 12 27 - 28 33 - 34 37 - 38	1 - 2 3 - 4 5 - 6	1 - 2 3 - 4 13 - 14 17 - 18

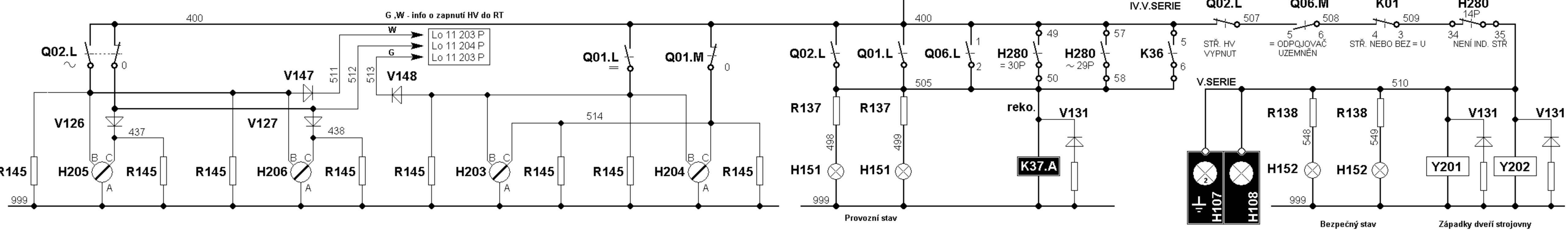

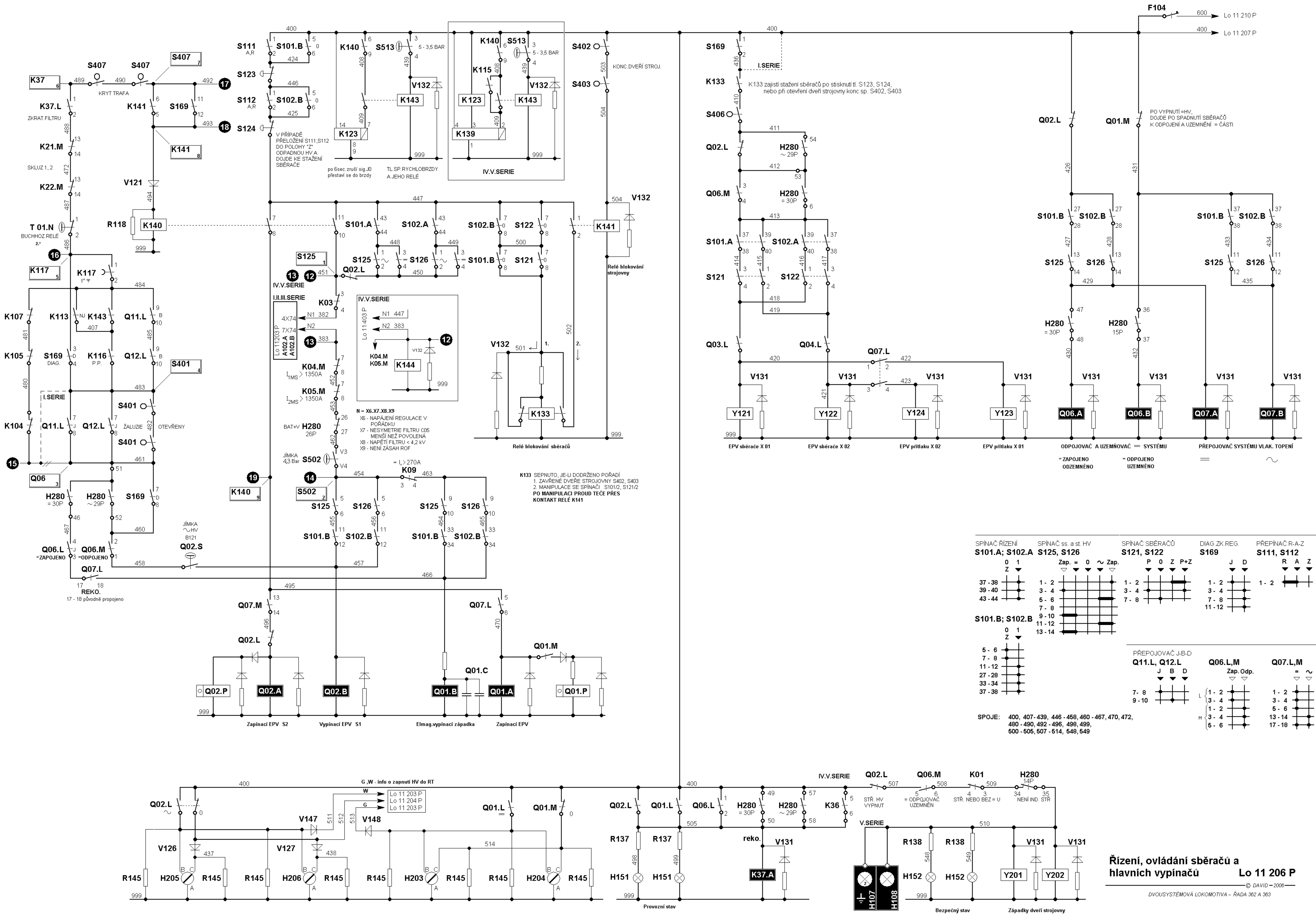

Rízení, ovládání sběračů a hlavních vypínačů
Lo 11 206 P

SPINAČ RÍZENÍ	SPINAČ ss. a st. HV	SPINAČ SBĚRAČŮ	DIAG. ZK. REG.	PŘEPÍNAČ R-A-Z
S101.A; S102.A	S125, S126	S121, S122	S169	S111, S112
0 1 Z	Zap. = 0 ~ Zap.	P 0 Z P+Z	J D	R A Z
37 - 38 39 - 40 43 - 44	1 - 2 3 - 4 5 - 6 7 - 8 9 - 10 11 - 12	1 - 2 3 - 4 7 - 8	1 - 2 3 - 4 7 - 8 11 - 12	1 - 2
S101.B; S102.B				
0 1 Z				
5 - 6 7 - 8 11 - 12 27 - 28 33 - 34 37 - 38				
SPOJĚ: 400, 407, 439, 446, 458, 460, 467, 470, 472, 480, 490, 492, 496, 498, 499, 500, 505, 507, 514, 548, 549				

PŘEPOJOVAČ J-B-D	Q06.L,M	Q07.L,M
Q11.L, Q12.L	Zap. Odp.	= ~
J B D		
7 - 8 11 - 12 27 - 28 33 - 34 37 - 38	1 - 2 3 - 4 5 - 6 13 - 14 17 - 18	1 - 2 3 - 4 5 - 6 13 - 14 17 - 18

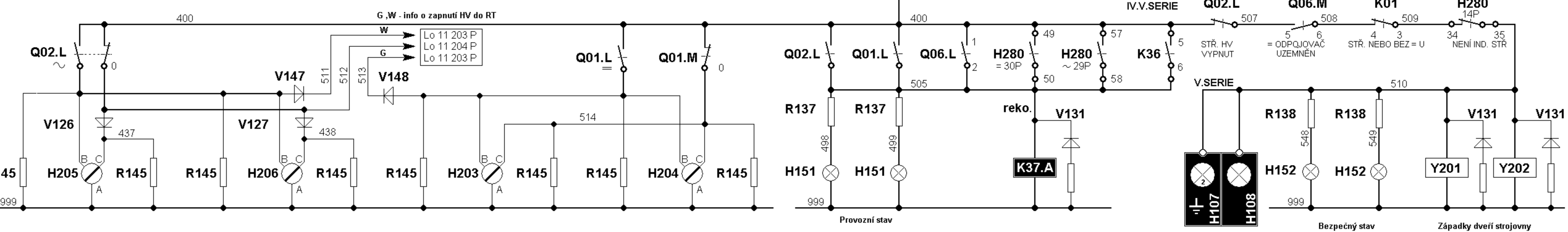

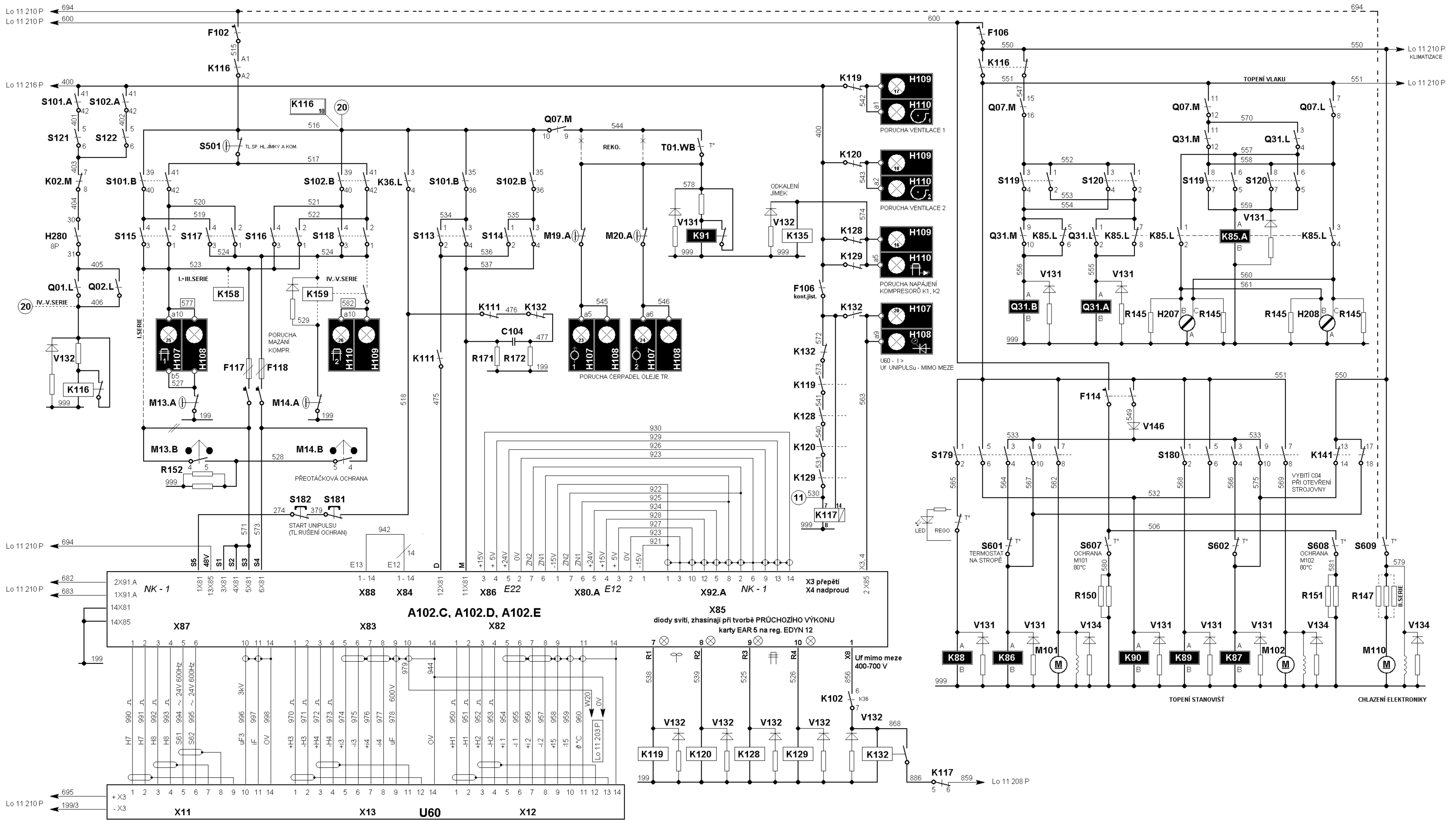

SPINAČ ŘÍZENÍ
S101.A; S102.A

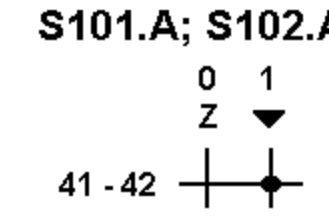

S101.B; S102.B

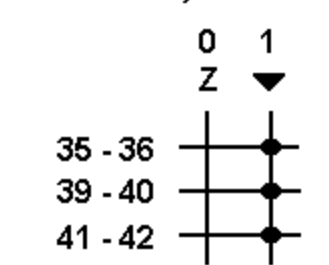

OVLADAČ VENTILÁTORŮ
S113, S114

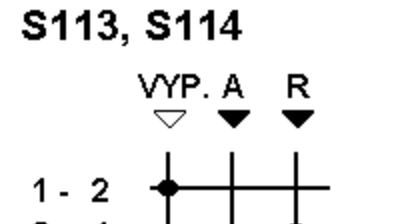

OVLADAČE KOMPRESORŮ
S115, S116

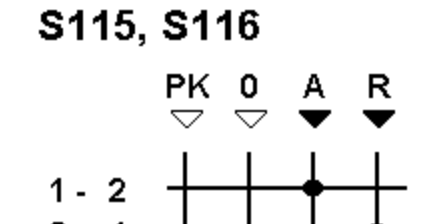

S117, S118

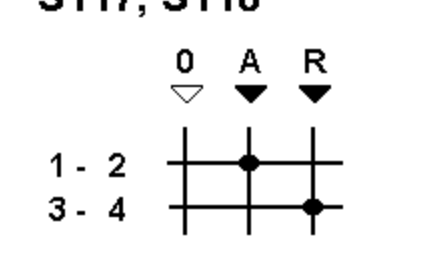

OVLADAČ TOPENÍ VLAKU
S119, S120

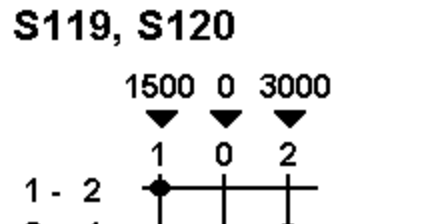

SPINAČ SBĚRAČŮ
S121, S122

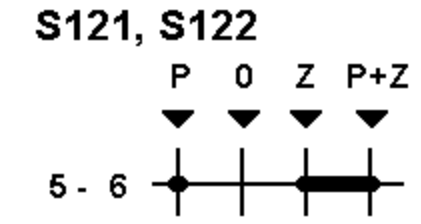

OVLADAČ TOPENÍ STANOVIŠTĚ
S179, S180

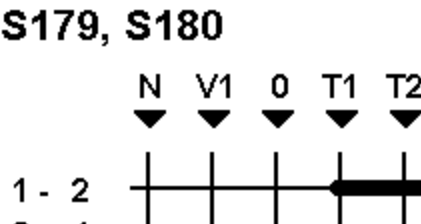

PŘEPOJOVAČE VLAKOVÉHO TOPENÍ
Q07.L, M Q31.L, M

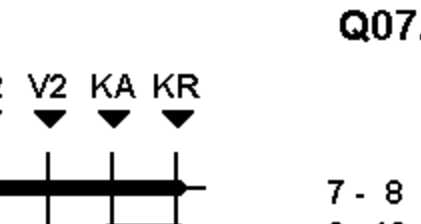

SPOJE : 274, 379, 401 - 406, 475 - 477, 506, 515 - 547, 549, 550 - 570 - 575, 578 - 581, 856, 868, 886, 921 - 930, 942, 944, 950 - 960, 970 - 979, 990 - 998

IV.-V.SERIE [577] [582]

Pomocné pohony, topení vlaku topení stanoviště Lo 11 207 P

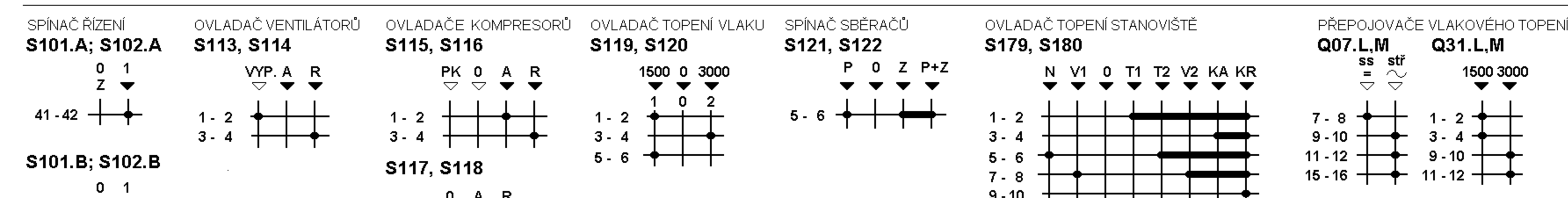
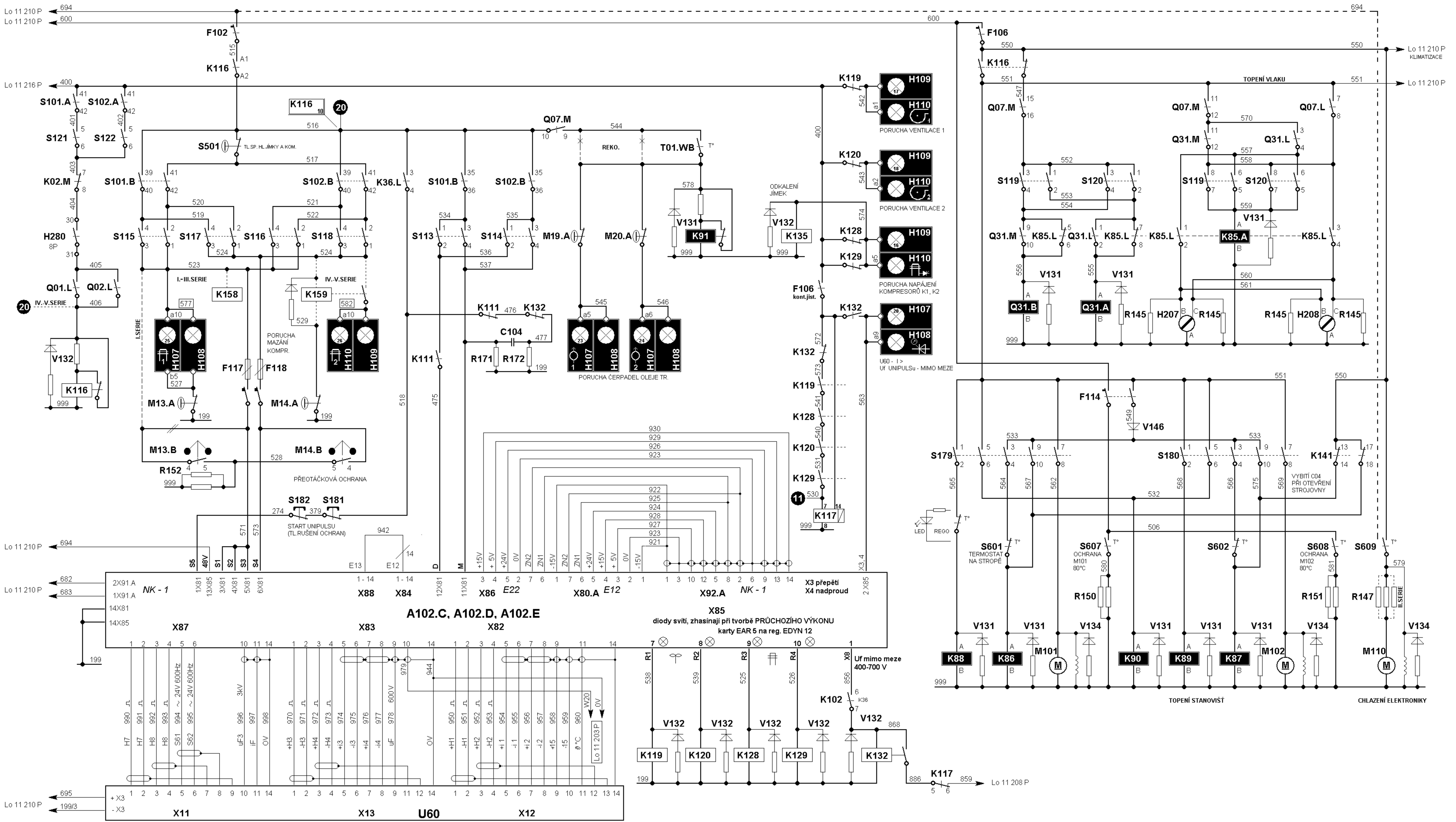

SPOJE : 274, 379, 401 - 406, 475 - 477, 506, 515 - 547, 549, 550 - 570 - 575, 578 - 581, 856, 868, 886, 921 - 930, 942, 944, 950 - 960, 970 - 979, 990 - 998

IV.-V.SERIE [577] [582]

**Pomocné pohony, topení vlaku
topení stanoviště** Lo 11 207 P

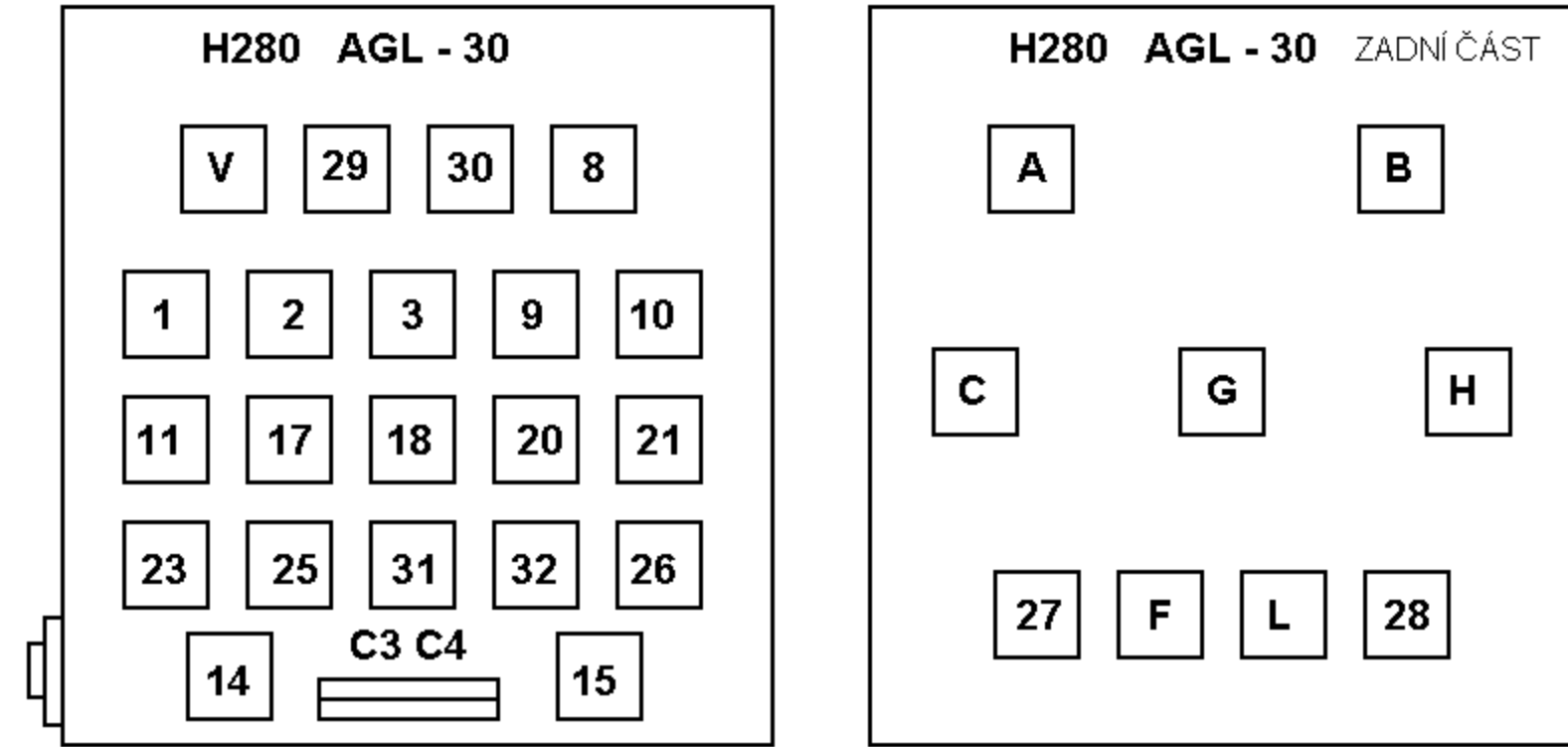
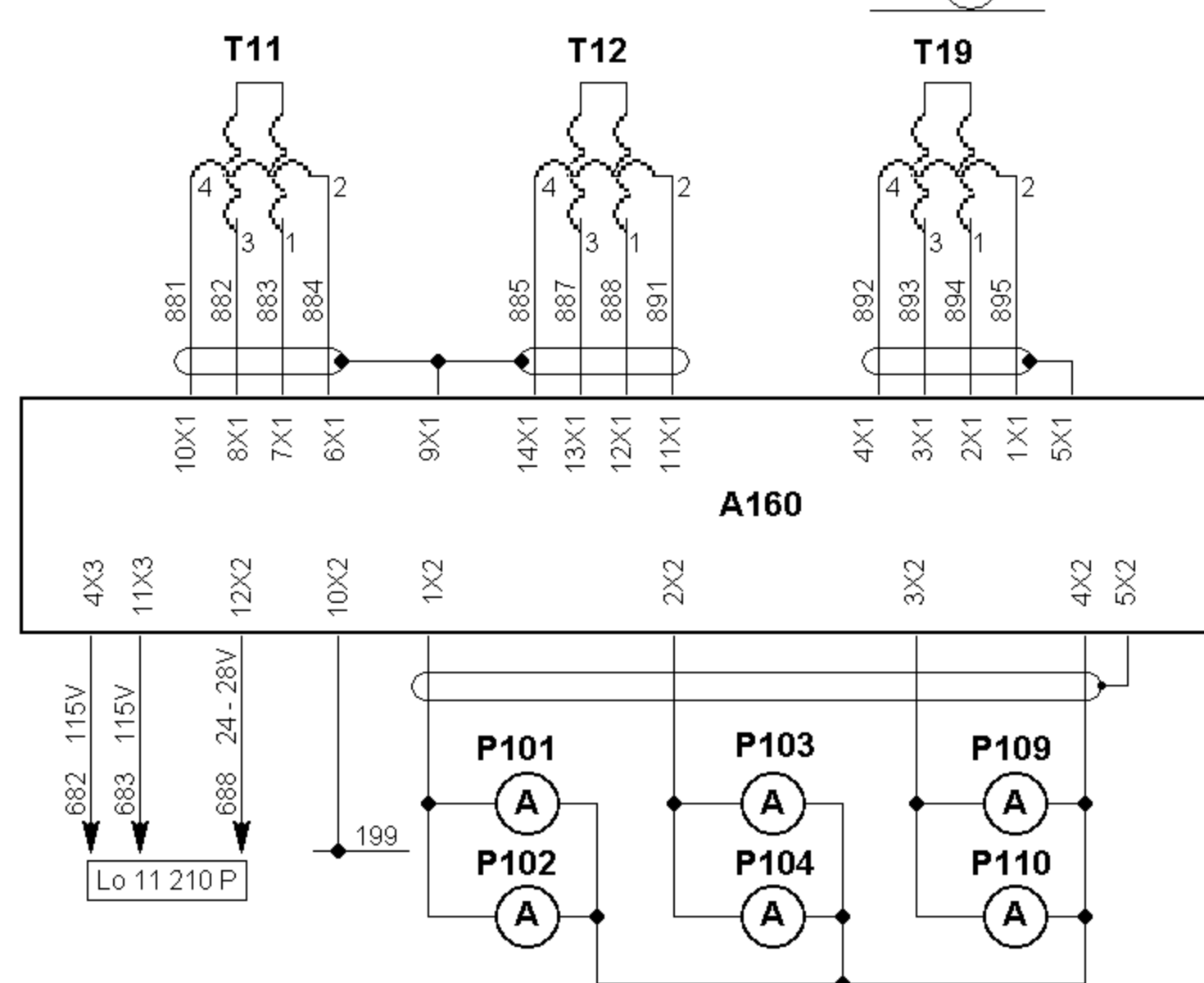
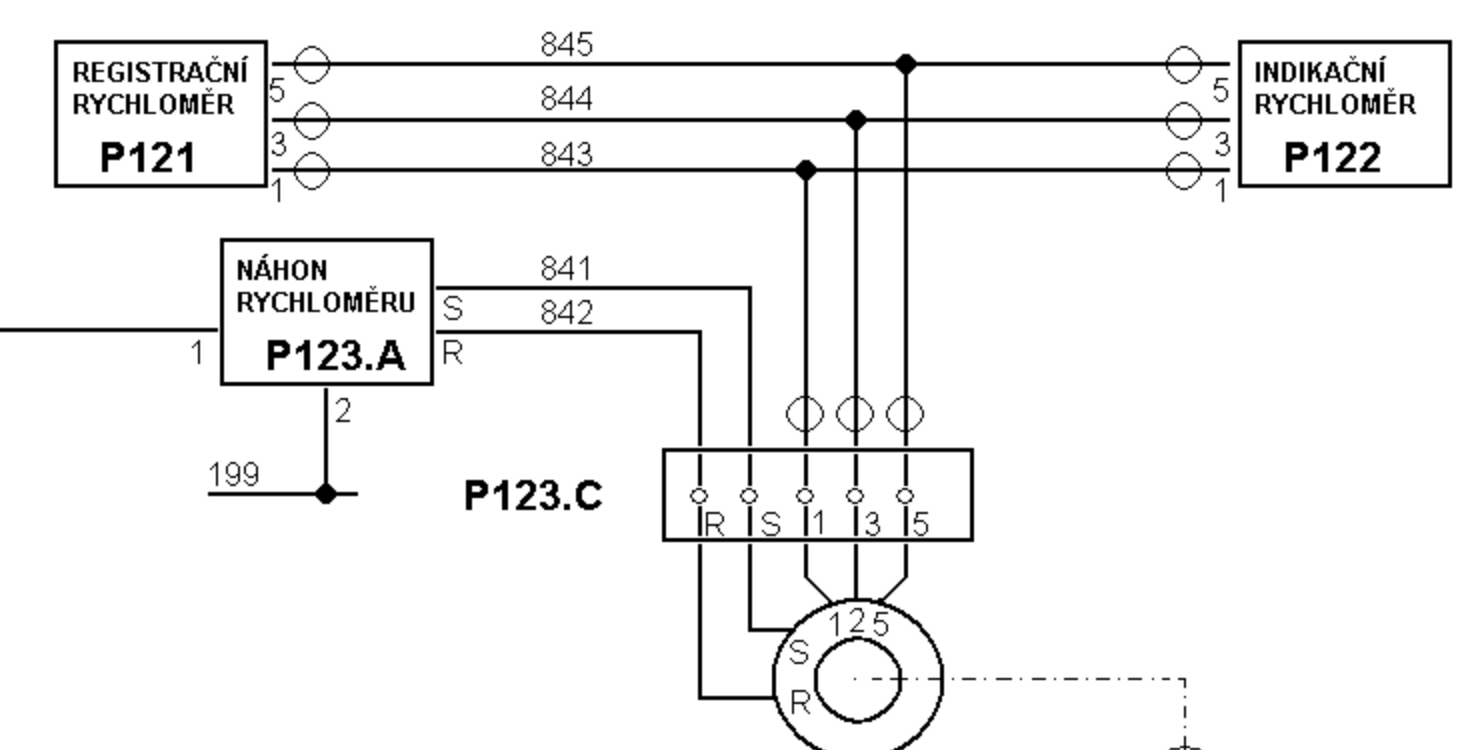
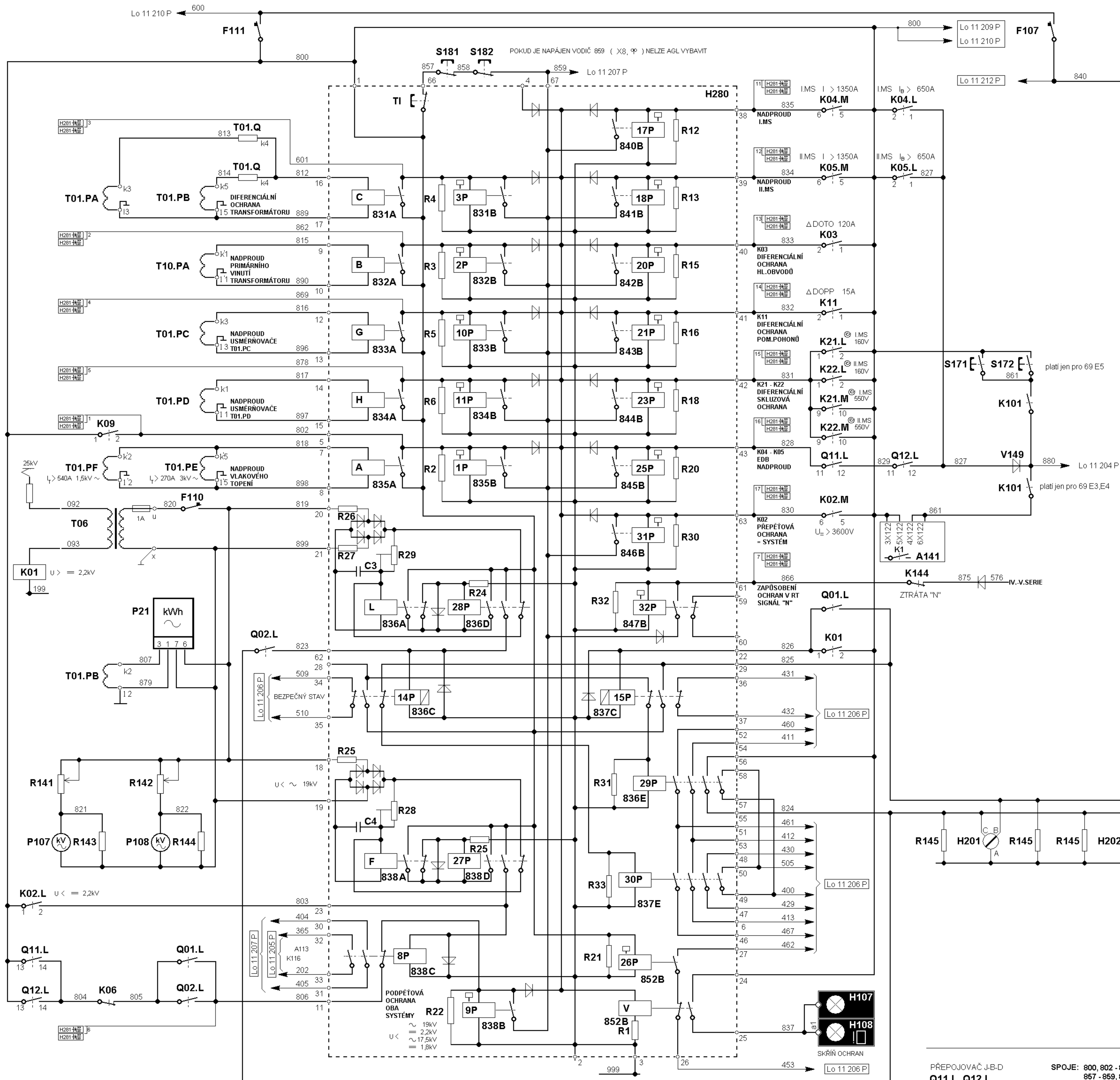

H281																					
1	2	3	4	5	6	7	8	9	10	11	12	13	14	15	16	17	18	19	20	21	22
802	862	601	869	878	806	866		835	834	833	834	831	828	830							999

H282																						
1	2	3	4	5	6	7	8	9	10	11	12	13	14	15	16	17	18	19	20	21	22	

- 1P NADPROUD TOPENÍ VLAKU K09, str. T01.PF NEBO T01.PE
- 2P NADPROUD PRIMÁRU TRAFU, str. T01.PA
- 3P DIF. OCHRANA PRIMÁRU TRAFU, str. T01.PA a T01.PB
- 9P PODPĚTÍ str. T06, ss. K02
- 10P NADPROUD 1.MŮSTKU USMĚRNOVAČE DIUS, str. T01.PC
- 11P NADPROUD 2.MŮSTKU USMĚRNOVAČE DIUS, str. T01.PD
- 17P NADPROUD 1.MS, K04.M I_k > 1350A
- 18P NADPROUD 2.MS, K05.M I_k > 1350A
- 21P DOTO K03 dif > 120A ss.
- 23P DOPP K11 dif > 15A ss.
- 25P SKLUZ (rozdílné napětí mezi K21.M a K22.M > 180V ss.)
- 26P NADPROUD EDB K04.L, K05.L I_k > 650A
- 28P NAPĚTÍ BAT.V PORÁDKU
- 31P PREPĚTÍ NA ss. SYS. K02.M > 3.8 kV
- 32P ZTRÁTA "N"
- V SOUČTOVÁ SIGNALIZACE

PLATÍ PRO IV.V.seri - ZOBRAZOVACÍ AGL JE NA STŘEDNÍM SLOUPKU PULTU

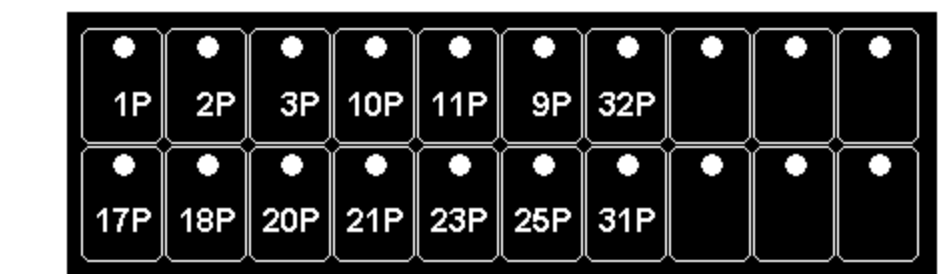

- 9P PODPĚTÍ ss. SYS.
- 32P ZTRÁTA "N" sig. K144 PLATÍ PRO IV.V.seri
- 23P NAPĚTÍ DIF. OCHRANA
- 31P NAPĚTÍ BAT.V PORÁDKU
- 32P NAPĚTÍ BAT.V PORÁDKU

PŘEPOJOVAČ J-B-D
Q11.L, Q12.L
 J B D
 11-12
 13-14

SPOJE: 800, 802 - 807, 812 - 835, 837, 840 - 845, 857 - 859, 870 - 873, 879, 881 - 885, 880, 887 - 899

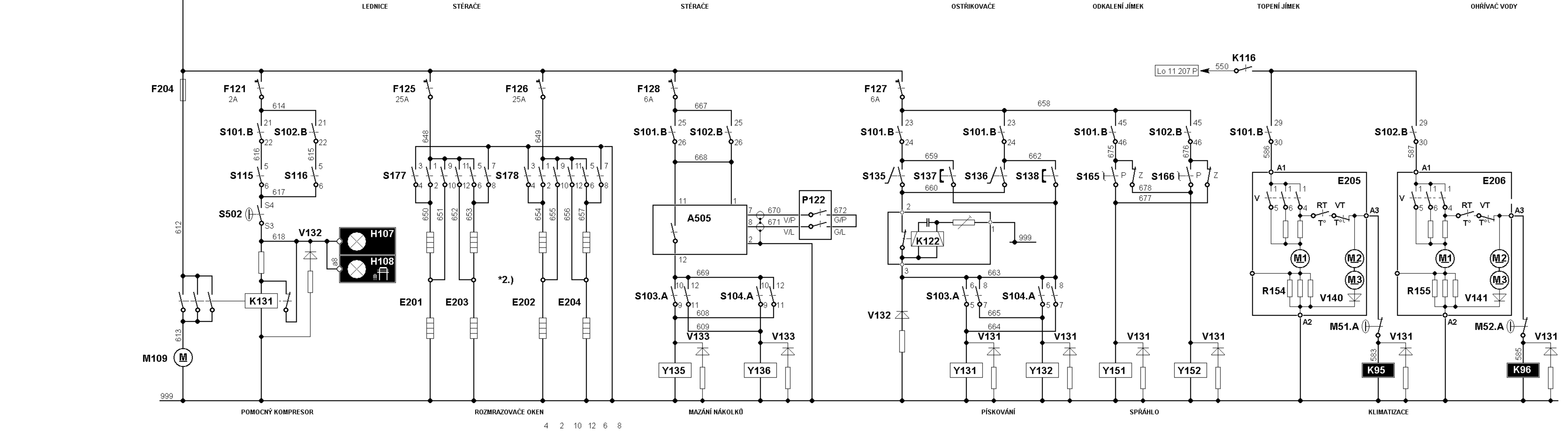
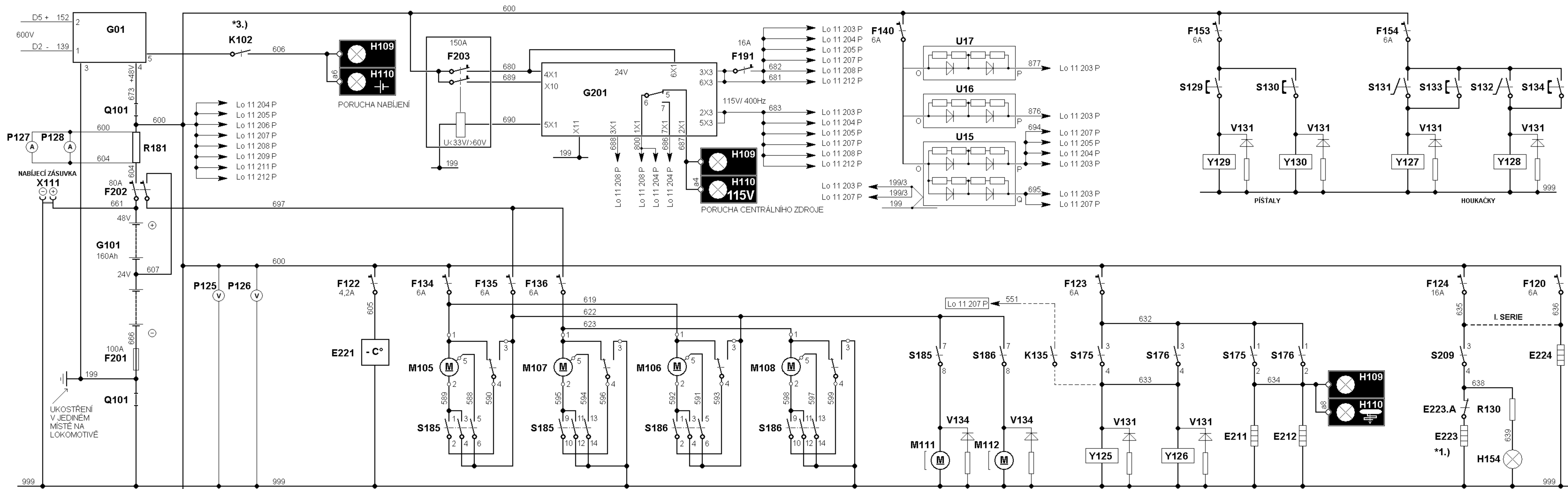

SPINAČ ŘÍZENÍ S101.B; S102.B	SMĚROVÁ PÁKA S103.A; S104.A	OVLAĐAČE KOMPRESORŮ S115, S116	OVLAĐAČ OHŘÍVAČE VODY S209	OVLAĐAČE STĚRAČŮ S185, S186	ROZMRAZOVAČE S177, S178	ODVODNĚNÍ JÍMEK S175, S176																																																																																																																															
<table border="1"> <tr><td>0</td><td>1</td></tr> <tr><td>Z</td><td>↓</td></tr> <tr><td>21-22</td><td>•</td></tr> <tr><td>23-24</td><td>•</td></tr> <tr><td>25-26</td><td>•</td></tr> <tr><td>45-46</td><td>•</td></tr> </table>	0	1	Z	↓	21-22	•	23-24	•	25-26	•	45-46	•	<table border="1"> <tr><td>Z</td><td>0</td><td>P</td></tr> <tr><td>5-6</td><td>•</td><td>•</td></tr> <tr><td>7-8</td><td>•</td><td>•</td></tr> <tr><td>9-10</td><td>•</td><td>•</td></tr> <tr><td>11-12</td><td>•</td><td>•</td></tr> </table>	Z	0	P	5-6	•	•	7-8	•	•	9-10	•	•	11-12	•	•	<table border="1"> <tr><td>PK</td><td>0</td><td>A</td><td>R</td></tr> <tr><td>5-6</td><td>•</td><td>•</td><td>•</td></tr> </table>	PK	0	A	R	5-6	•	•	•	<table border="1"> <tr><td>0</td><td>Z</td><td>0</td><td>Z</td></tr> <tr><td>3-4</td><td>•</td><td>•</td><td>•</td></tr> </table>	0	Z	0	Z	3-4	•	•	•	<table border="1"> <tr><td>I+OS</td><td>I</td><td>0</td><td>II</td><td>II+OS</td></tr> <tr><td>1-2</td><td>•</td><td>•</td><td>•</td><td>•</td></tr> <tr><td>3-4</td><td>•</td><td>•</td><td>•</td><td>•</td></tr> <tr><td>5-6</td><td>•</td><td>•</td><td>•</td><td>•</td></tr> <tr><td>7-8</td><td>•</td><td>•</td><td>•</td><td>•</td></tr> <tr><td>9-10</td><td>•</td><td>•</td><td>•</td><td>•</td></tr> <tr><td>11-12</td><td>•</td><td>•</td><td>•</td><td>•</td></tr> <tr><td>13-14</td><td>•</td><td>•</td><td>•</td><td>•</td></tr> </table>	I+OS	I	0	II	II+OS	1-2	•	•	•	•	3-4	•	•	•	•	5-6	•	•	•	•	7-8	•	•	•	•	9-10	•	•	•	•	11-12	•	•	•	•	13-14	•	•	•	•	<table border="1"> <tr><td>0</td><td>I.</td><td>II.</td><td>III.</td></tr> <tr><td>1-2</td><td>•</td><td>•</td><td>•</td></tr> <tr><td>3-4</td><td>•</td><td>•</td><td>•</td></tr> <tr><td>5-6</td><td>•</td><td>•</td><td>•</td></tr> <tr><td>7-8</td><td>•</td><td>•</td><td>•</td></tr> <tr><td>9-10</td><td>•</td><td>•</td><td>•</td></tr> <tr><td>11-12</td><td>•</td><td>•</td><td>•</td></tr> <tr><td>13-14</td><td>•</td><td>•</td><td>•</td></tr> </table>	0	I.	II.	III.	1-2	•	•	•	3-4	•	•	•	5-6	•	•	•	7-8	•	•	•	9-10	•	•	•	11-12	•	•	•	13-14	•	•	•	<table border="1"> <tr><td>V</td><td>0</td><td>T</td><td>V+T</td></tr> <tr><td>1-2</td><td>•</td><td>•</td><td>•</td></tr> <tr><td>3-4</td><td>•</td><td>•</td><td>•</td></tr> </table>	V	0	T	V+T	1-2	•	•	•	3-4	•	•	•
0	1																																																																																																																																				
Z	↓																																																																																																																																				
21-22	•																																																																																																																																				
23-24	•																																																																																																																																				
25-26	•																																																																																																																																				
45-46	•																																																																																																																																				
Z	0	P																																																																																																																																			
5-6	•	•																																																																																																																																			
7-8	•	•																																																																																																																																			
9-10	•	•																																																																																																																																			
11-12	•	•																																																																																																																																			
PK	0	A	R																																																																																																																																		
5-6	•	•	•																																																																																																																																		
0	Z	0	Z																																																																																																																																		
3-4	•	•	•																																																																																																																																		
I+OS	I	0	II	II+OS																																																																																																																																	
1-2	•	•	•	•																																																																																																																																	
3-4	•	•	•	•																																																																																																																																	
5-6	•	•	•	•																																																																																																																																	
7-8	•	•	•	•																																																																																																																																	
9-10	•	•	•	•																																																																																																																																	
11-12	•	•	•	•																																																																																																																																	
13-14	•	•	•	•																																																																																																																																	
0	I.	II.	III.																																																																																																																																		
1-2	•	•	•																																																																																																																																		
3-4	•	•	•																																																																																																																																		
5-6	•	•	•																																																																																																																																		
7-8	•	•	•																																																																																																																																		
9-10	•	•	•																																																																																																																																		
11-12	•	•	•																																																																																																																																		
13-14	•	•	•																																																																																																																																		
V	0	T	V+T																																																																																																																																		
1-2	•	•	•																																																																																																																																		
3-4	•	•	•																																																																																																																																		

SPOJE : 582 - 599, 600, 603, 605 - 609, 612 - 619, 622, 623, 630 - 636, 638, 639, 642 - 673, 675 - 678, 680 - 683, 686 - 690, 694 - 697, 876, 877

POTENCIÁLY VODIČŮ : 600 +48V, 199 -48V, 999 -48V, 607 +24V, 681, 682, 683 115V/400Hz

*1.) ZMĚNA V OBVODĚ E223
 *2.) U LOK. S LEPENÝMI SKLY JSOU SONDY K161 - K164 NA TEMPEROVÁNÍ PROTI OROSENÍ
 *3.) PORUCHA NABÍJEČE PŘES K102