

**Řízení, regulátor tahu,
skluzová ochrana** Lo 11 203 P

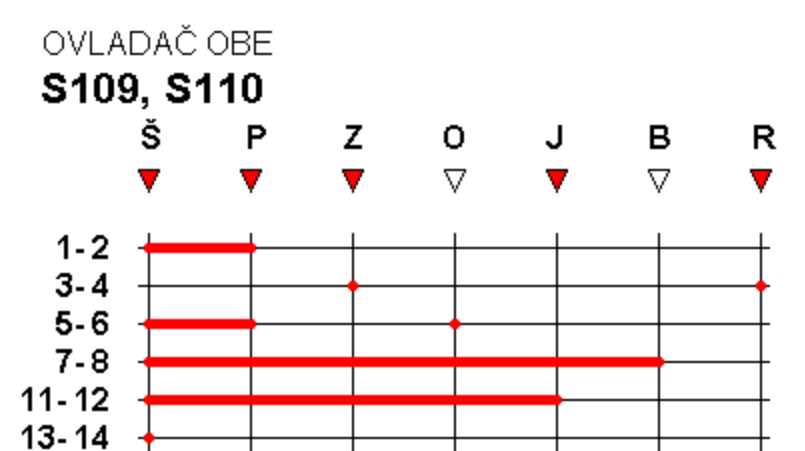
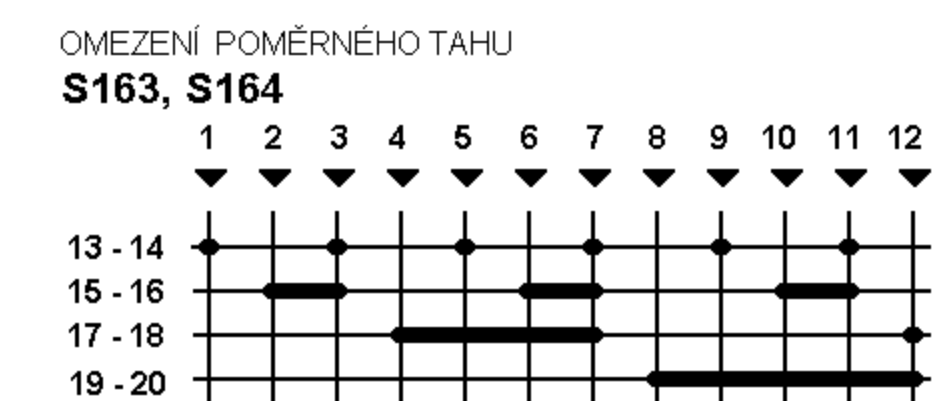
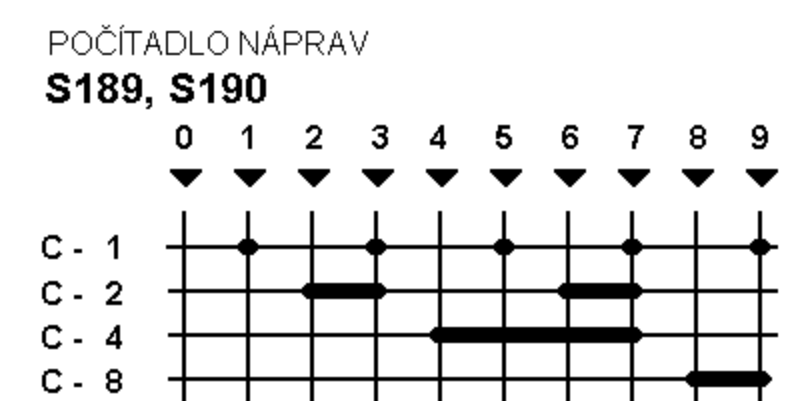
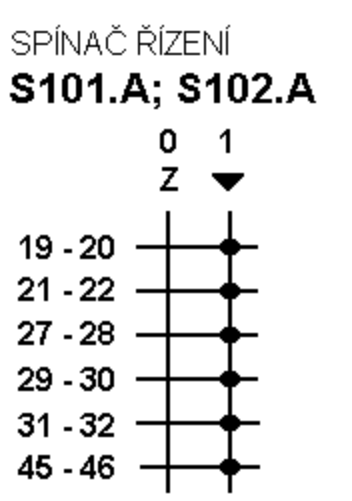
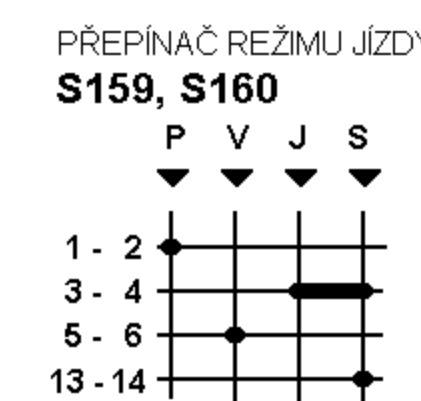
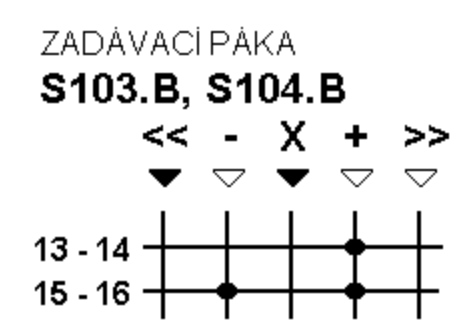
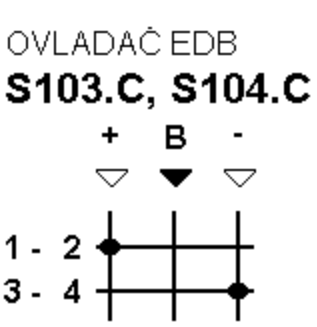
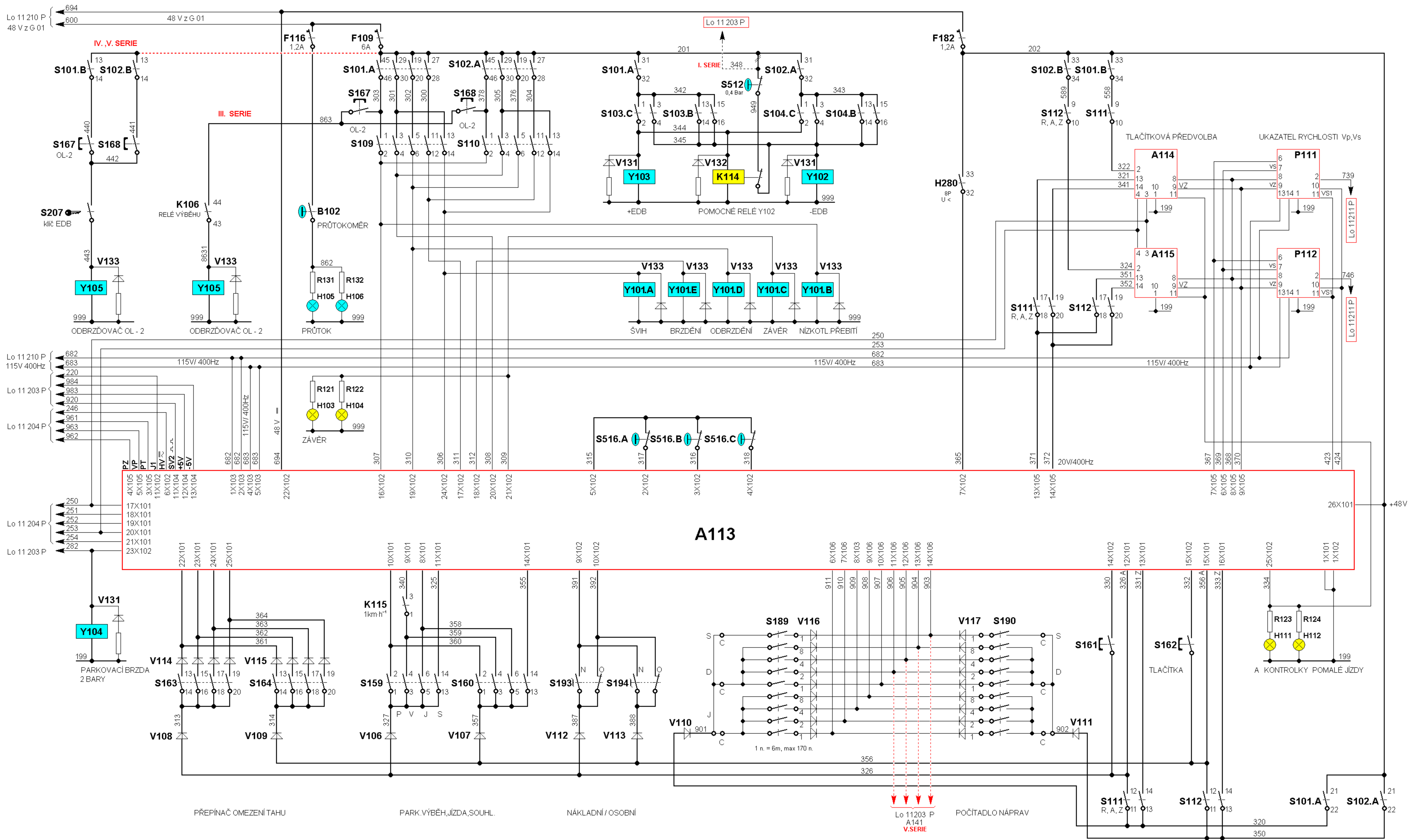

SPOJE: 201, 202, 300 - 312, 315 - 318, 320, 321, 325 - 327, 340 - 345, 355 - 365, 367 - 372, 376, 378, 387, 388, 391, 392, 901 - 911, 944, 945, 961, 962, 949

PLNÍČÍ ŠVIH
NÍZKOTLAKÉ PŘEBÍTÍ
ZÁVĚR
PROVOZNÍ ODBRZDĚNÍ
JÍZDA
PROVOZNÍ BRZDĚNÍ
RYCHLOČINNÉ BRZDĚNÍ
7- 8 k elektronickému rychloměru

Řízení, regulátor rychlosti a elektropneumatická brzda Lo 11 205 P

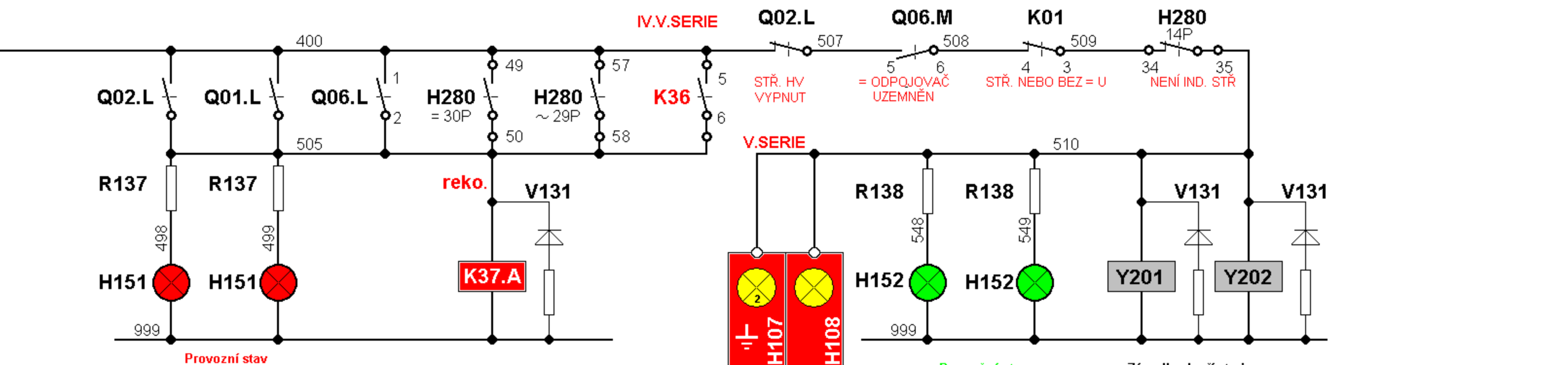
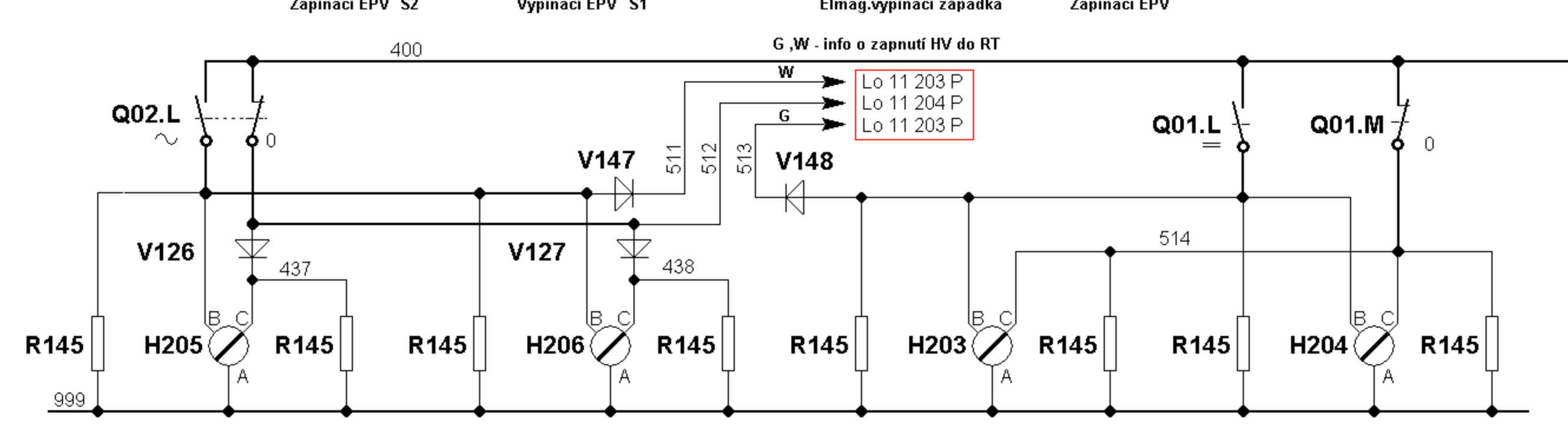
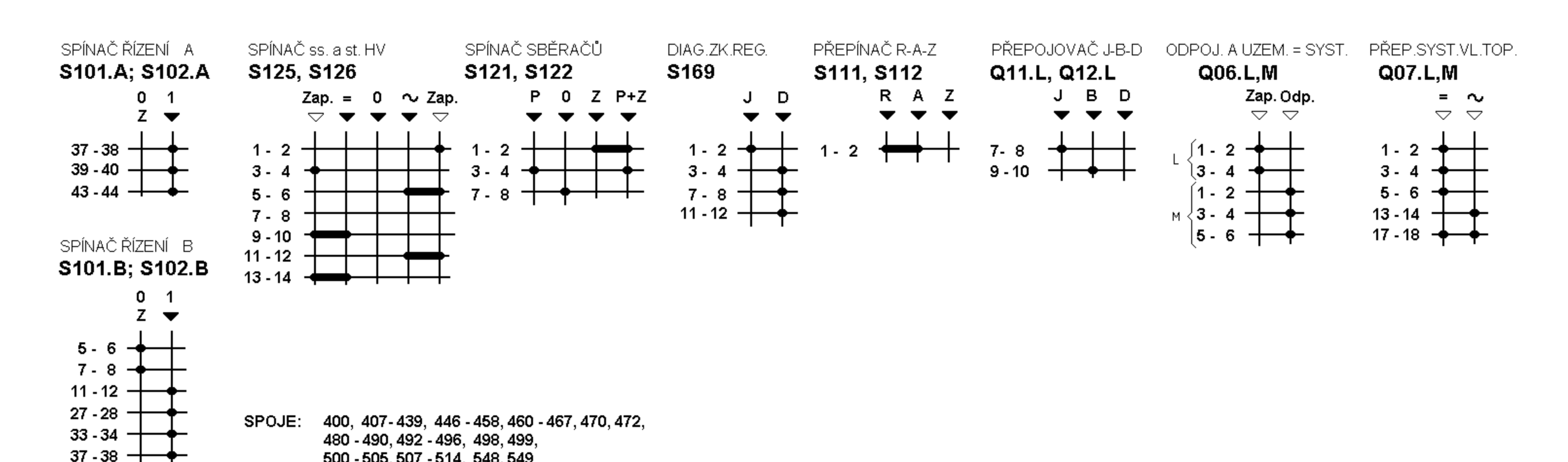
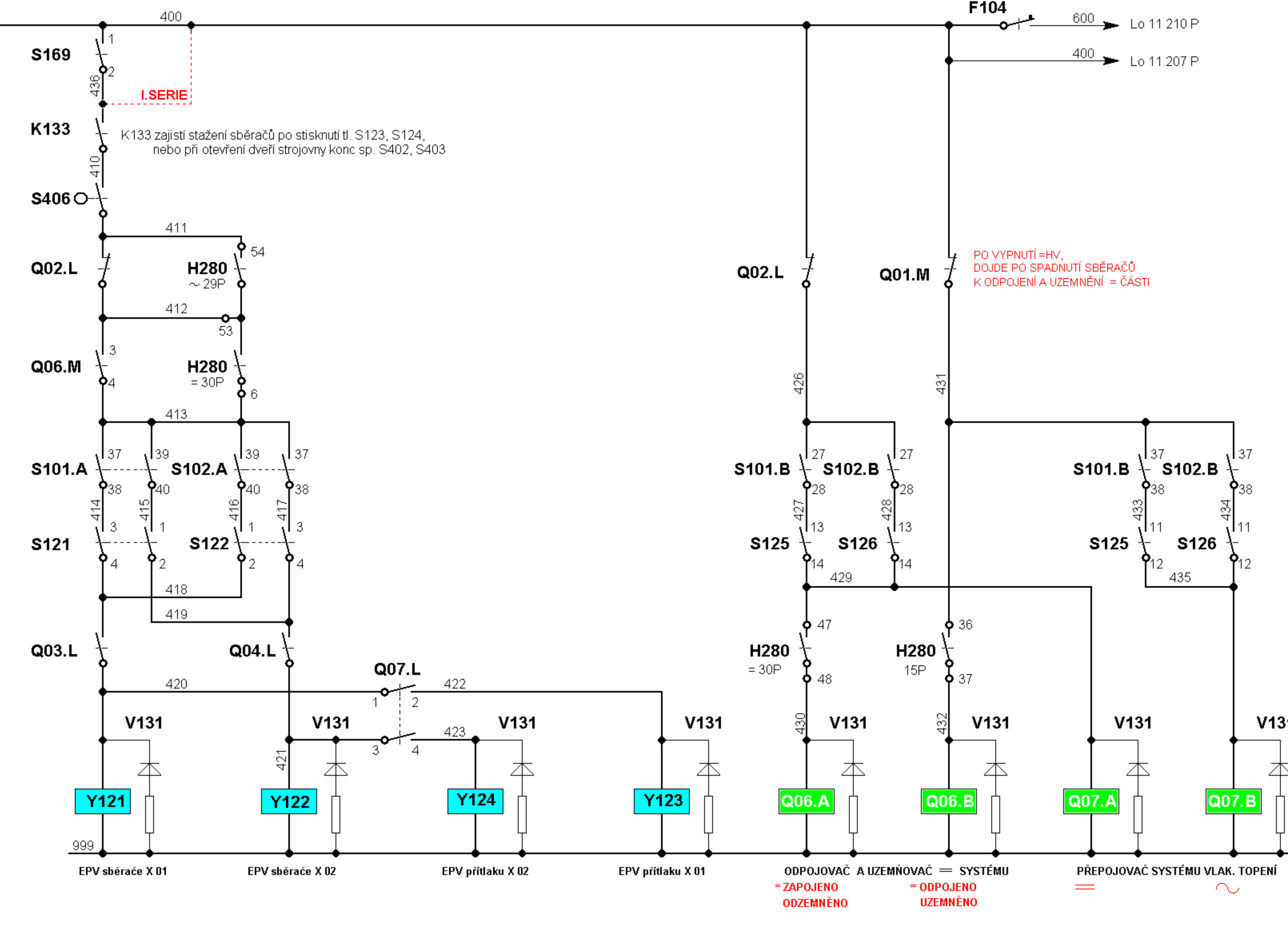
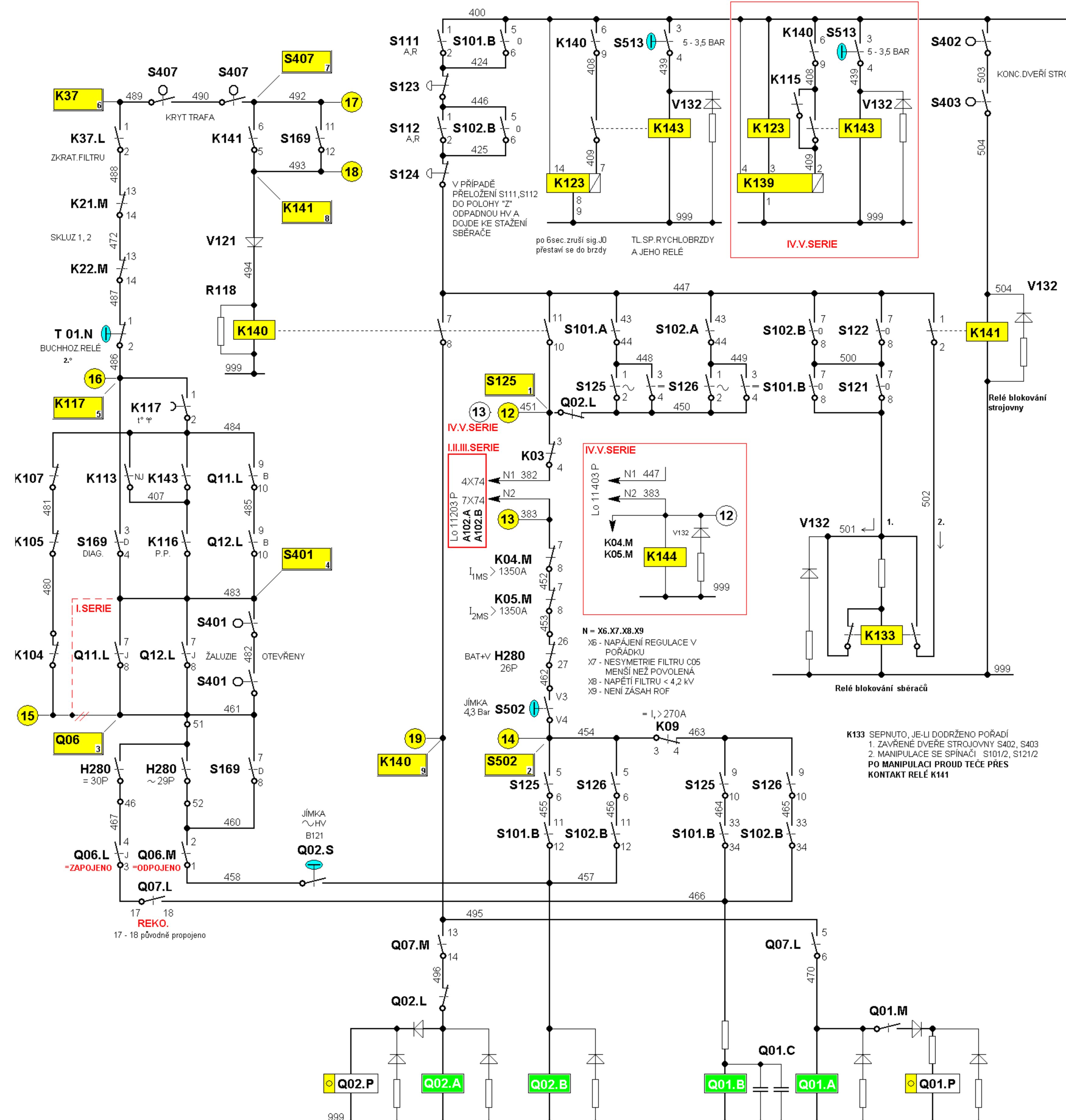

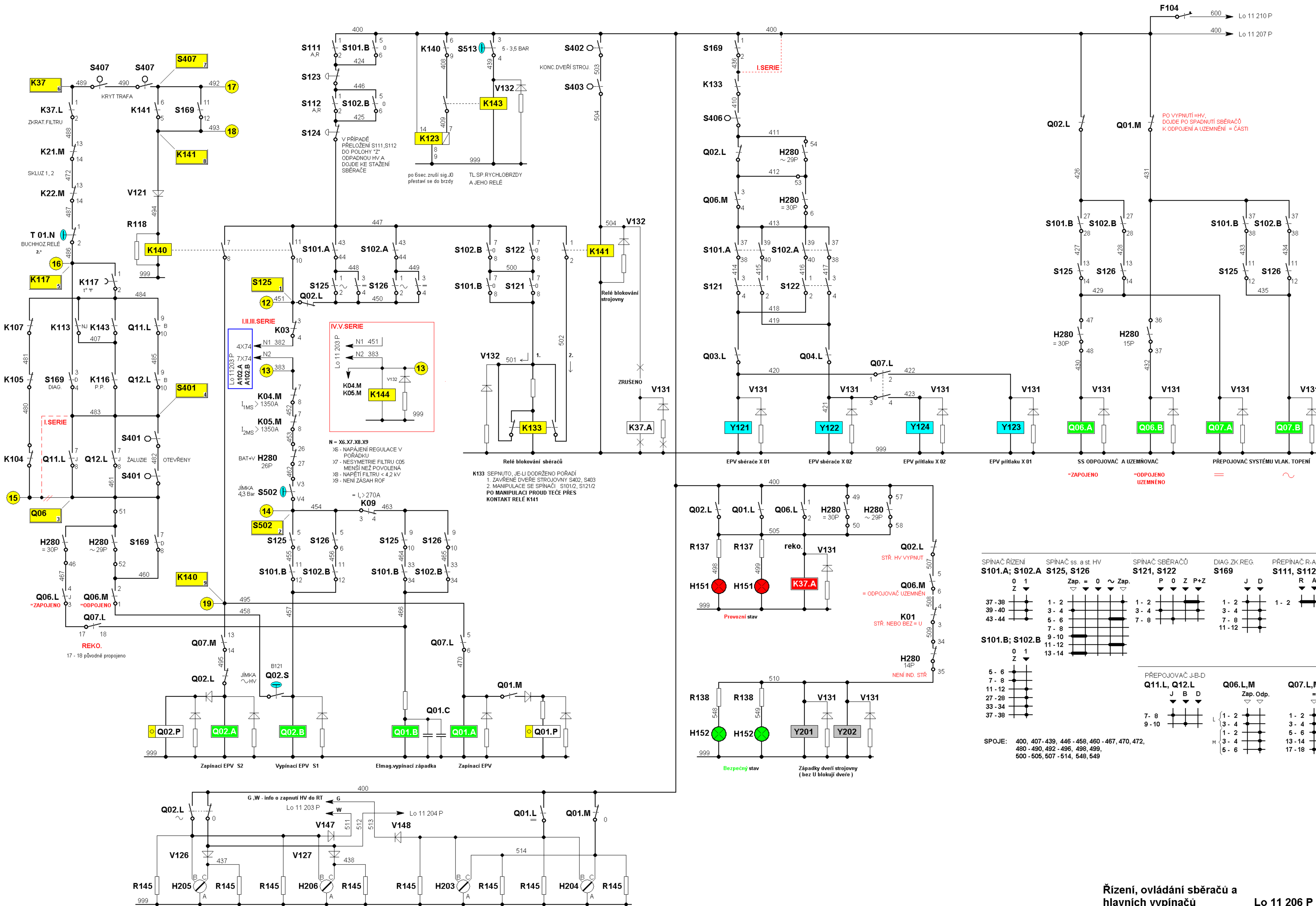

SPINAČ ŘÍZENÍ	SPINAČ ss. a st. HV	SPINAČ SBĚRAČŮ	DIAG. ZK. REG.	PŘEPOVAČ R-A-Z																																																																																	
S101.A; S102.A	S125, S126	S121, S122	S169	S111, S112																																																																																	
<table border="1"> <tr><td>0</td><td>1</td></tr> <tr><td>Z</td><td>Z</td></tr> <tr><td>37-38</td><td>1-2</td></tr> <tr><td>39-40</td><td>3-4</td></tr> <tr><td>43-44</td><td>5-6</td></tr> <tr><td>7-8</td><td>7-8</td></tr> <tr><td>9-10</td><td>9-10</td></tr> <tr><td>11-12</td><td>11-12</td></tr> </table>	0	1	Z	Z	37-38	1-2	39-40	3-4	43-44	5-6	7-8	7-8	9-10	9-10	11-12	11-12	<table border="1"> <tr><td>Zap.</td><td>=</td><td>0</td><td>~</td><td>Zap.</td></tr> <tr><td>1-2</td><td></td><td></td><td></td><td></td></tr> <tr><td>3-4</td><td></td><td></td><td></td><td></td></tr> <tr><td>5-6</td><td></td><td></td><td></td><td></td></tr> <tr><td>7-8</td><td></td><td></td><td></td><td></td></tr> <tr><td>9-10</td><td></td><td></td><td></td><td></td></tr> <tr><td>11-12</td><td></td><td></td><td></td><td></td></tr> <tr><td>13-14</td><td></td><td></td><td></td><td></td></tr> </table>	Zap.	=	0	~	Zap.	1-2					3-4					5-6					7-8					9-10					11-12					13-14					<table border="1"> <tr><td>P</td><td>0</td><td>Z</td><td>P+Z</td></tr> <tr><td>1-2</td><td></td><td></td><td></td></tr> <tr><td>3-4</td><td></td><td></td><td></td></tr> <tr><td>7-8</td><td></td><td></td><td></td></tr> </table>	P	0	Z	P+Z	1-2				3-4				7-8				<table border="1"> <tr><td>J</td><td>D</td></tr> <tr><td>1-2</td><td></td></tr> <tr><td>3-4</td><td></td></tr> <tr><td>7-8</td><td></td></tr> <tr><td>11-12</td><td></td></tr> </table>	J	D	1-2		3-4		7-8		11-12	
0	1																																																																																				
Z	Z																																																																																				
37-38	1-2																																																																																				
39-40	3-4																																																																																				
43-44	5-6																																																																																				
7-8	7-8																																																																																				
9-10	9-10																																																																																				
11-12	11-12																																																																																				
Zap.	=	0	~	Zap.																																																																																	
1-2																																																																																					
3-4																																																																																					
5-6																																																																																					
7-8																																																																																					
9-10																																																																																					
11-12																																																																																					
13-14																																																																																					
P	0	Z	P+Z																																																																																		
1-2																																																																																					
3-4																																																																																					
7-8																																																																																					
J	D																																																																																				
1-2																																																																																					
3-4																																																																																					
7-8																																																																																					
11-12																																																																																					
<table border="1"> <tr><td>0</td><td>1</td></tr> <tr><td>Z</td><td>Z</td></tr> <tr><td>5-6</td><td></td></tr> <tr><td>7-8</td><td></td></tr> <tr><td>11-12</td><td></td></tr> <tr><td>27-28</td><td></td></tr> <tr><td>33-34</td><td></td></tr> <tr><td>37-38</td><td></td></tr> </table>	0	1	Z	Z	5-6		7-8		11-12		27-28		33-34		37-38		<table border="1"> <tr><td>J</td><td>B</td><td>D</td></tr> <tr><td>Zap.</td><td>Od.</td><td></td></tr> <tr><td>7-8</td><td></td><td></td></tr> <tr><td>9-10</td><td></td><td></td></tr> </table>	J	B	D	Zap.	Od.		7-8			9-10			<table border="1"> <tr><td>J</td><td>A</td><td>Z</td></tr> <tr><td>1-2</td><td></td><td></td></tr> <tr><td>3-4</td><td></td><td></td></tr> <tr><td>5-6</td><td></td><td></td></tr> <tr><td>13-14</td><td></td><td></td></tr> <tr><td>17-18</td><td></td><td></td></tr> </table>	J	A	Z	1-2			3-4			5-6			13-14			17-18																																							
0	1																																																																																				
Z	Z																																																																																				
5-6																																																																																					
7-8																																																																																					
11-12																																																																																					
27-28																																																																																					
33-34																																																																																					
37-38																																																																																					
J	B	D																																																																																			
Zap.	Od.																																																																																				
7-8																																																																																					
9-10																																																																																					
J	A	Z																																																																																			
1-2																																																																																					
3-4																																																																																					
5-6																																																																																					
13-14																																																																																					
17-18																																																																																					

SPOJE: 400, 407-439, 446-458, 460-467, 470, 472, 480-490, 492-496, 498, 499, 500-505, 507-514, 548, 549

Řízení, ovládání sběračů a hlavních vypínačů

Lo 11 206 P

© DAVID - 2006

DVOUSYSTÉMOVÁ LOKOMOTIVA - ŘADA 362 A 363

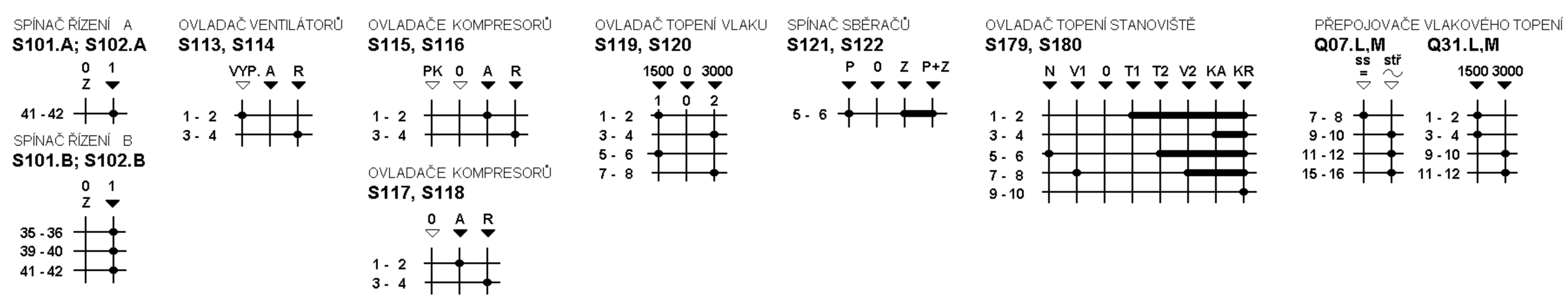
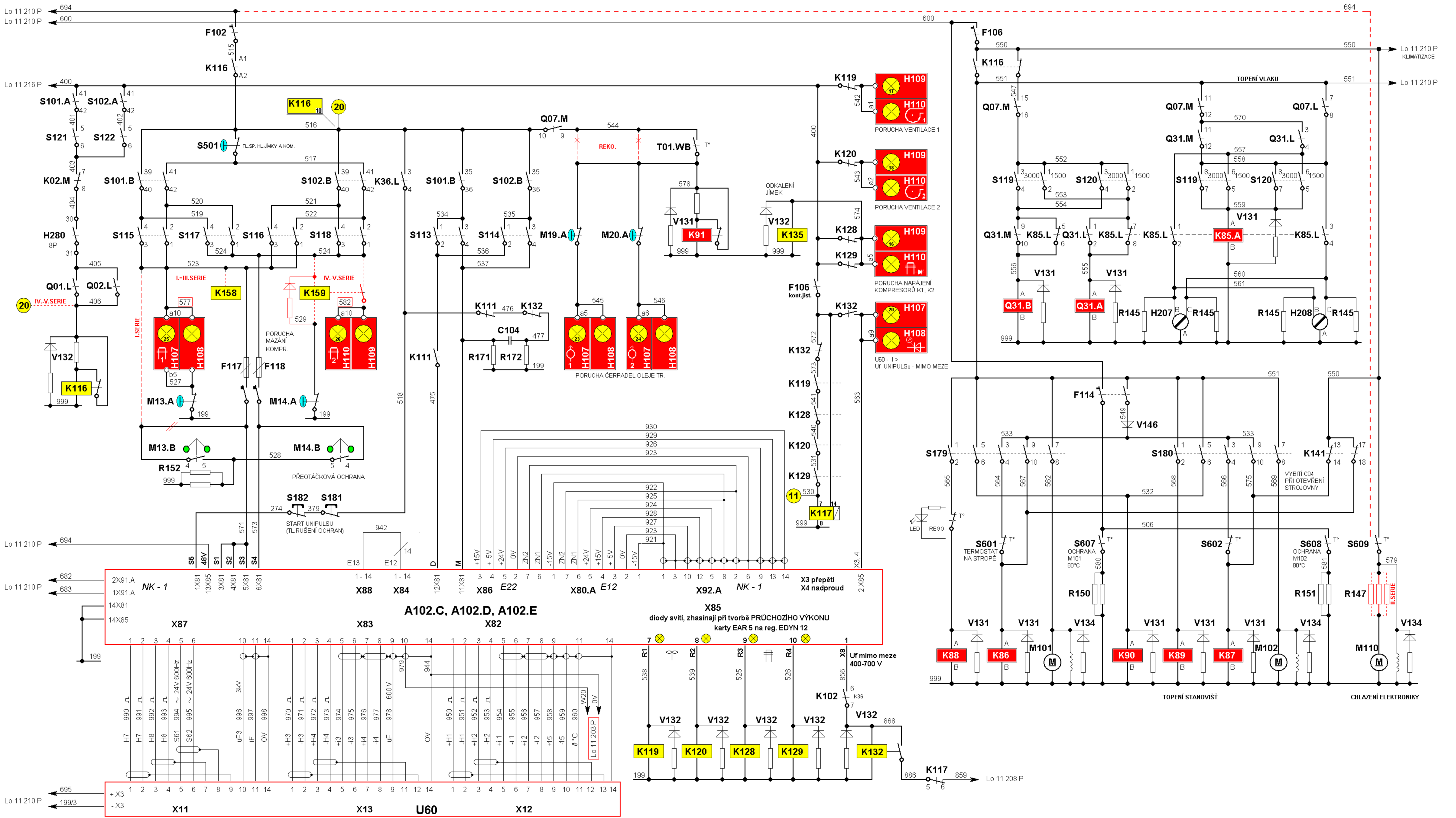

SPOJE : 274, 379, 401 - 406, 475 - 477, 506, 515 - 547, 549, 550 - 570 - 575, 578 - 581, 586, 588, 886, 921 - 930, 942, 944, 950 - 960, 970 - 979, 990 - 998

IV.V.SERIE [577] [582]

Pomocné pohony, topení vlaku topení stanoviště Lo 11 207 P

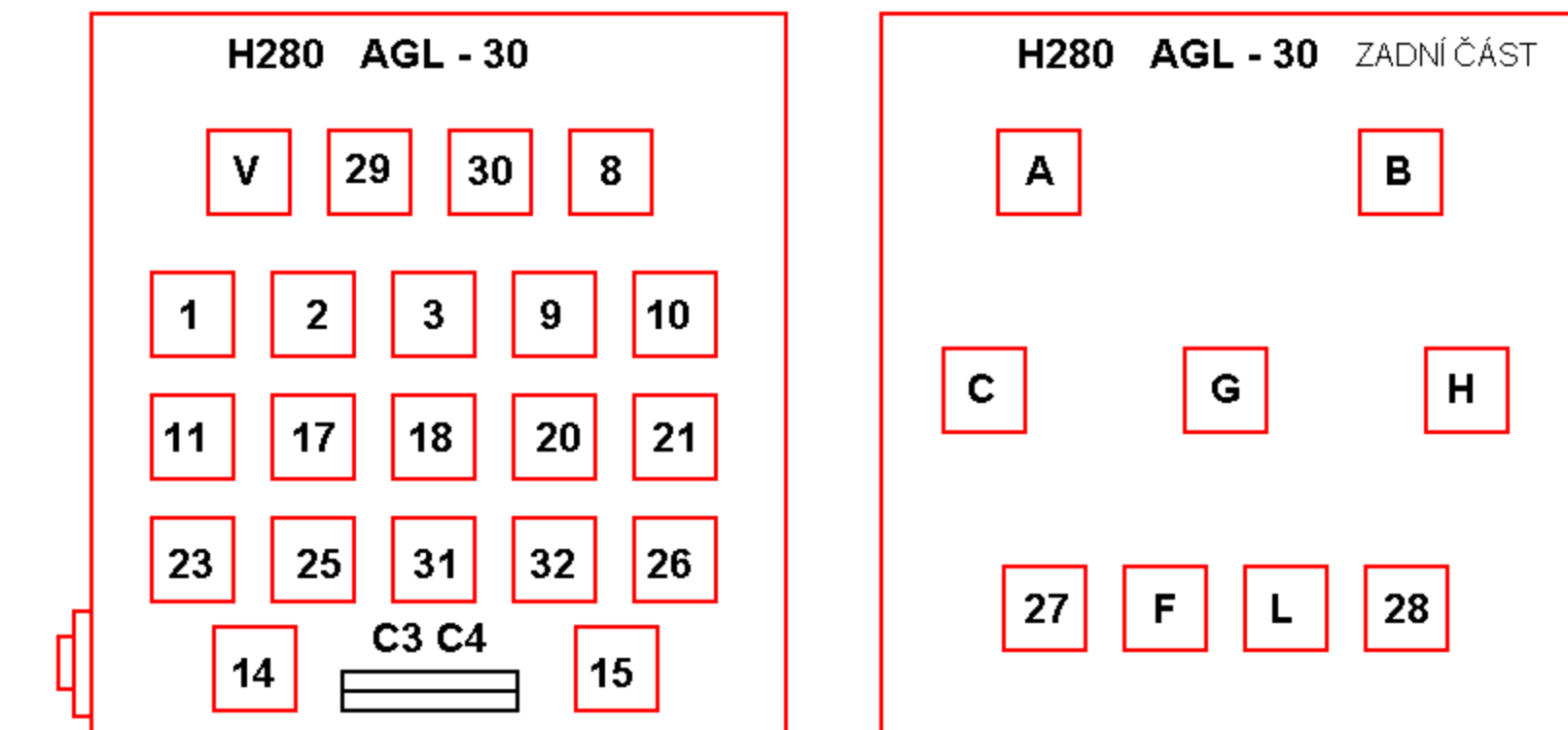
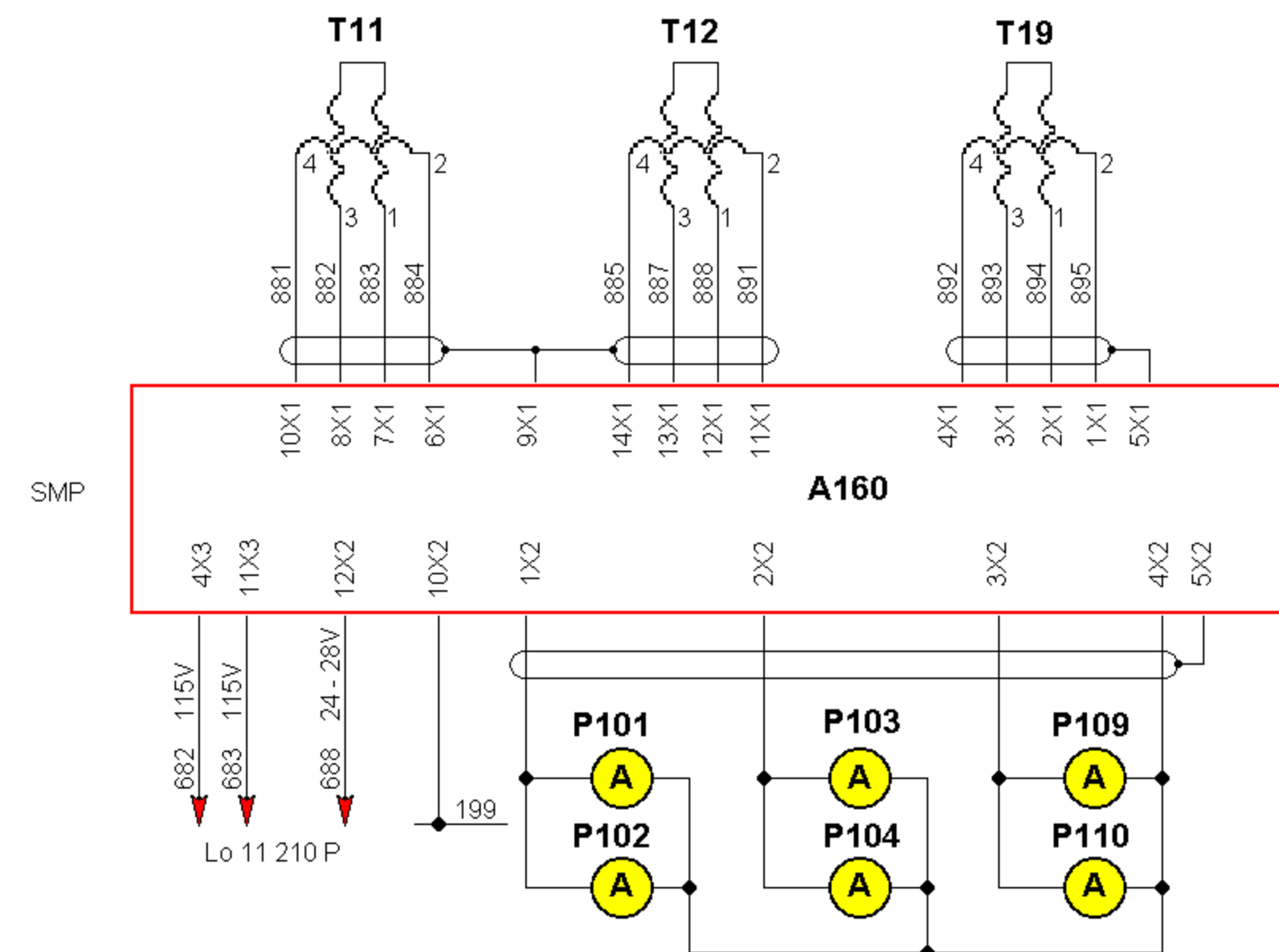
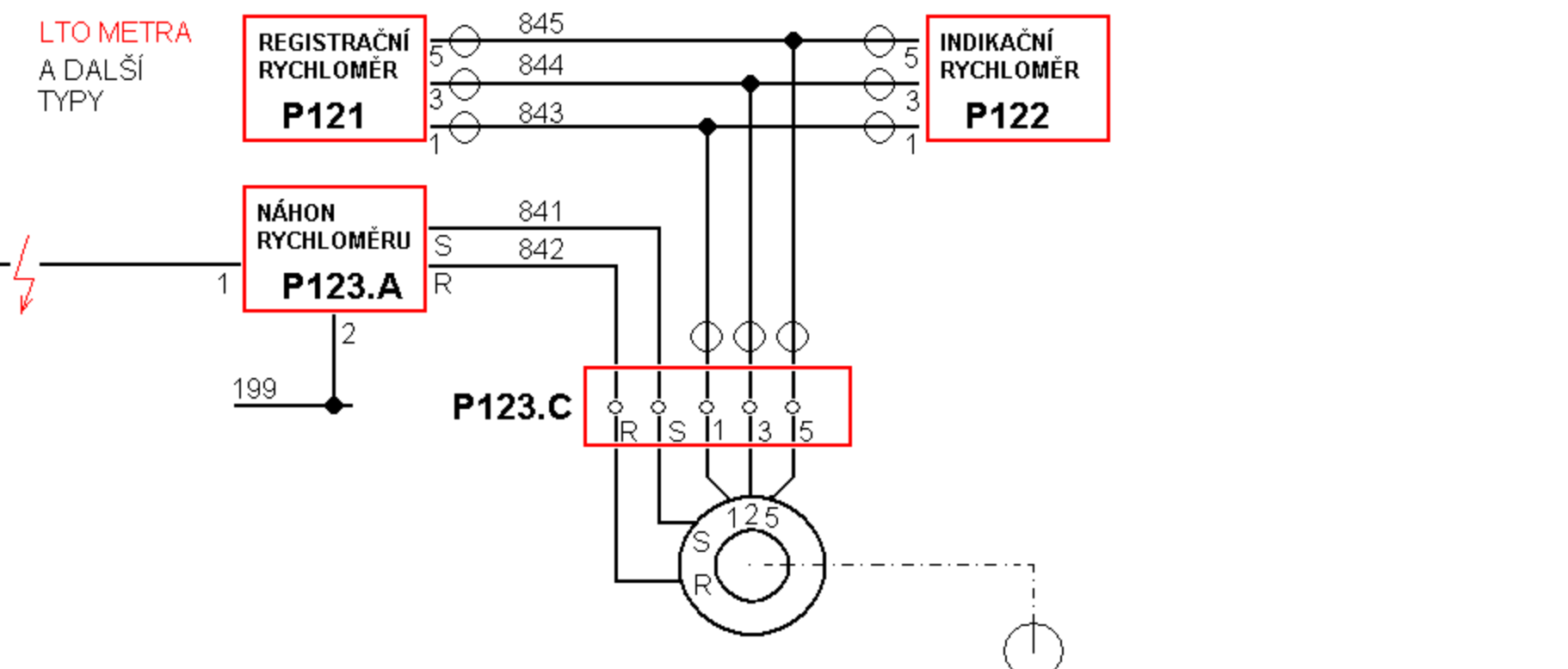
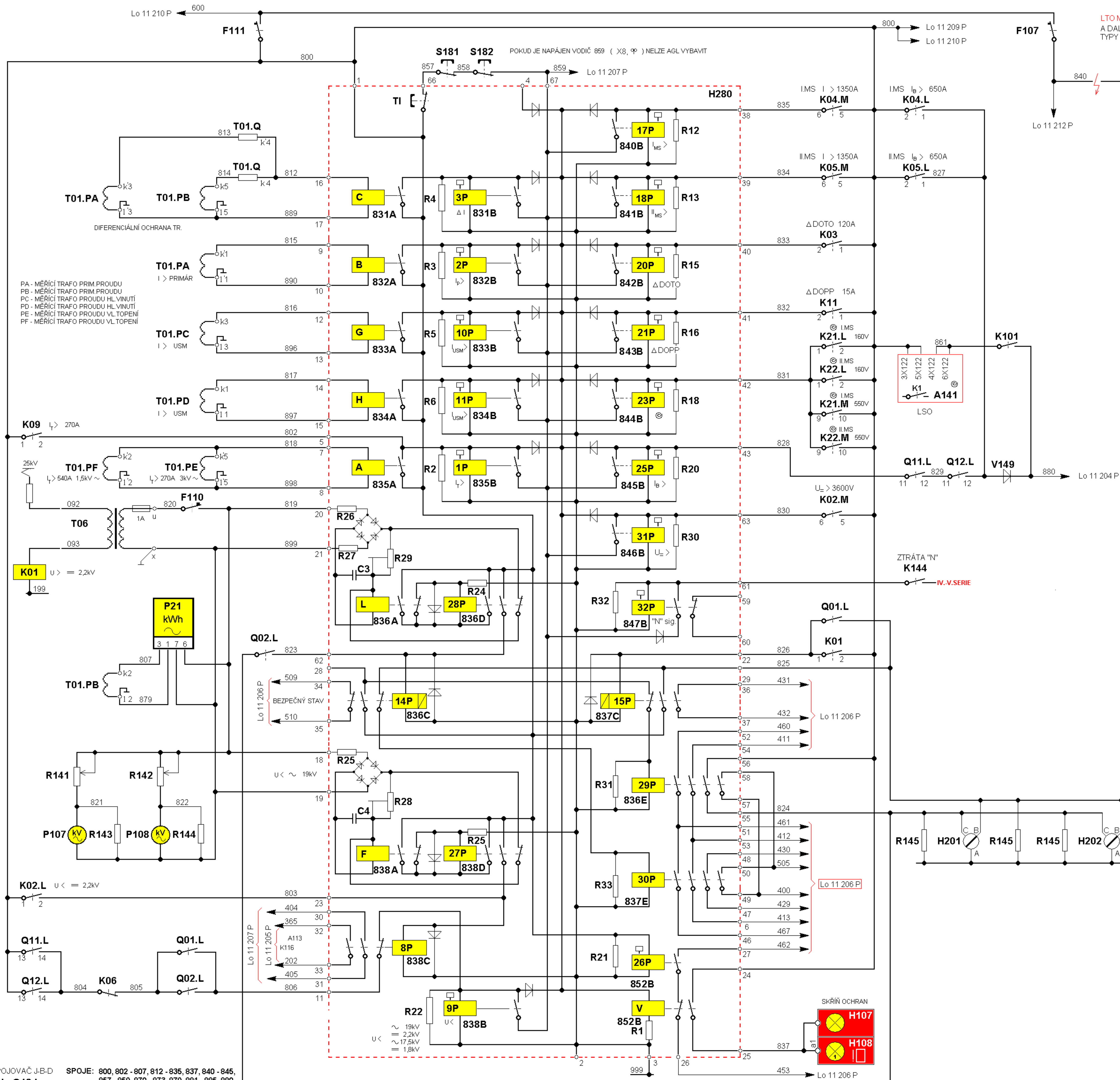

- 1P NADPROUD TOPENÍ VLAKU K09, str. T01.PF NEBO T01.PE
- 2P NADPROUD PRIMÁRU TRAFU; str. T01.PA
- 3P DIF. OCHRANA PRIMÁRU TRAFU; str. T01.PA a T01.PB
- 9P PODPĚTÍ str. T06, ss. K02
- 10P NADPROUD 1.MŮSTKU USMĚRŇOVAČE DIUS; str. T01.PC
- 11P NADPROUD 2.MŮSTKU USMĚRŇOVAČE DIUS; str. T01.PD
- 17P NADPROUD 1.MS; K04.M lk > 1350A
- 18P NADPROUD 2.MS; K05.M lk > 1350A
- 20P DOTO K03 dif > 120A ss.
- 21P DOPP K11 dif > 15A ss.
- 23P SKLUZ (rozílí napětí mezi K21.M a K22.M > 180V ss.
- 25P NADPROUD EDB K04.L; K05.L lk > 650 A
- 26P NAPĚTÍ BAT.V POŘÁDKU
- 28P PREPĚTÍ NA ss.SYS K02.M > 3.8 kV
- 31P
- V SOUČTOVÁ SIGNALIZACE

PLATÍ PRO IV.V.serii - ZOBRAZOVAČ AGL JE NA STŘEDNÍM SLOUPKU PULTU



- 9P PODPĚTÍ ss.SYS
- 32P ZTRÁTA "N" sig. K144 PLATÍ PRO IV.V.serii
- 23P NAPĚTOVÁ DIF. OCHRANA
- 31P NAPĚTOVÁ OCHRANA
- 28P NAPĚTÍ BAT.V POŘÁDKU

PRÉPOJOVAČ J-B-D SPOJĚ: 800, 802 - 807, 812 - 835, 837, 840 - 845, 857 - 859, 870 - 873, 879, 881 - 885, 880, 887 - 899

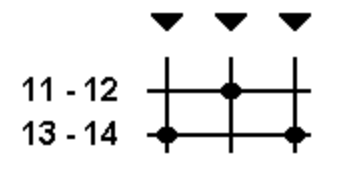

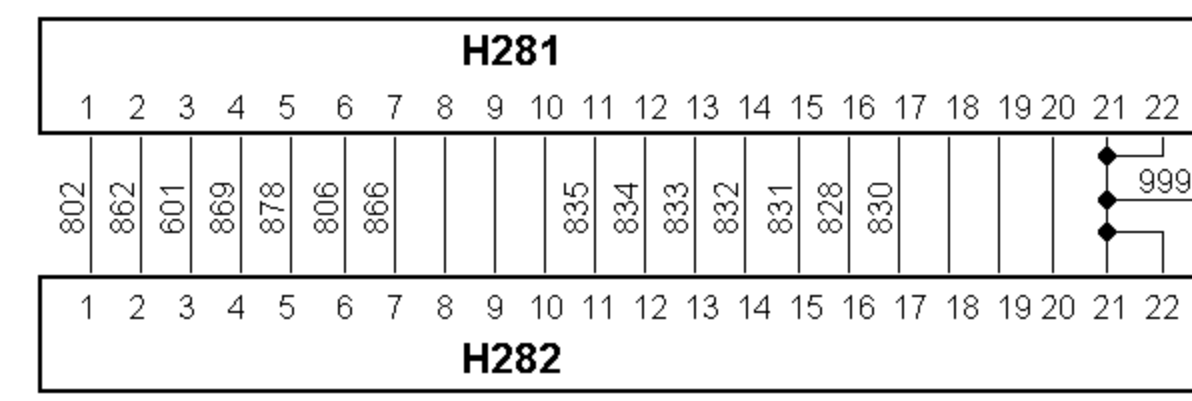
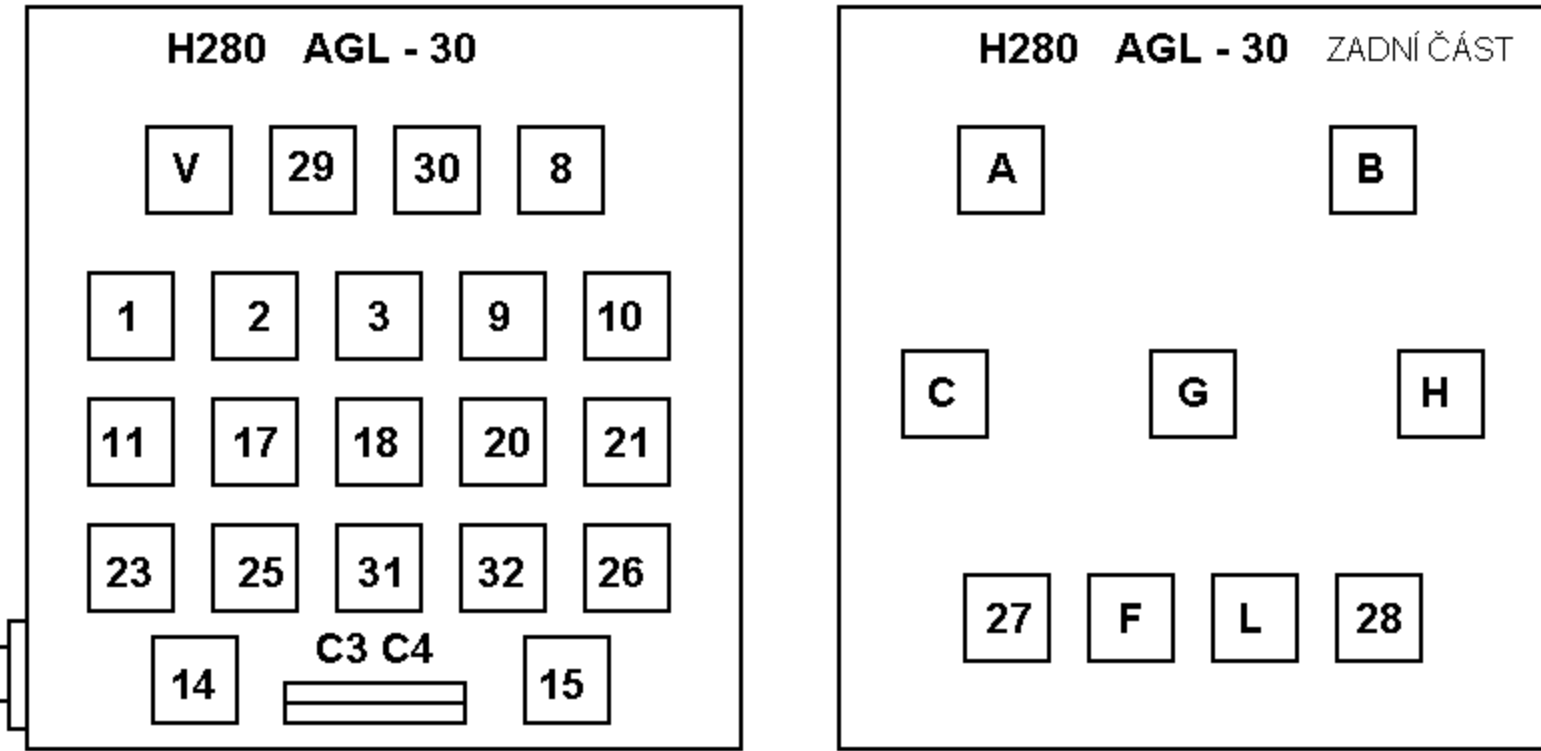
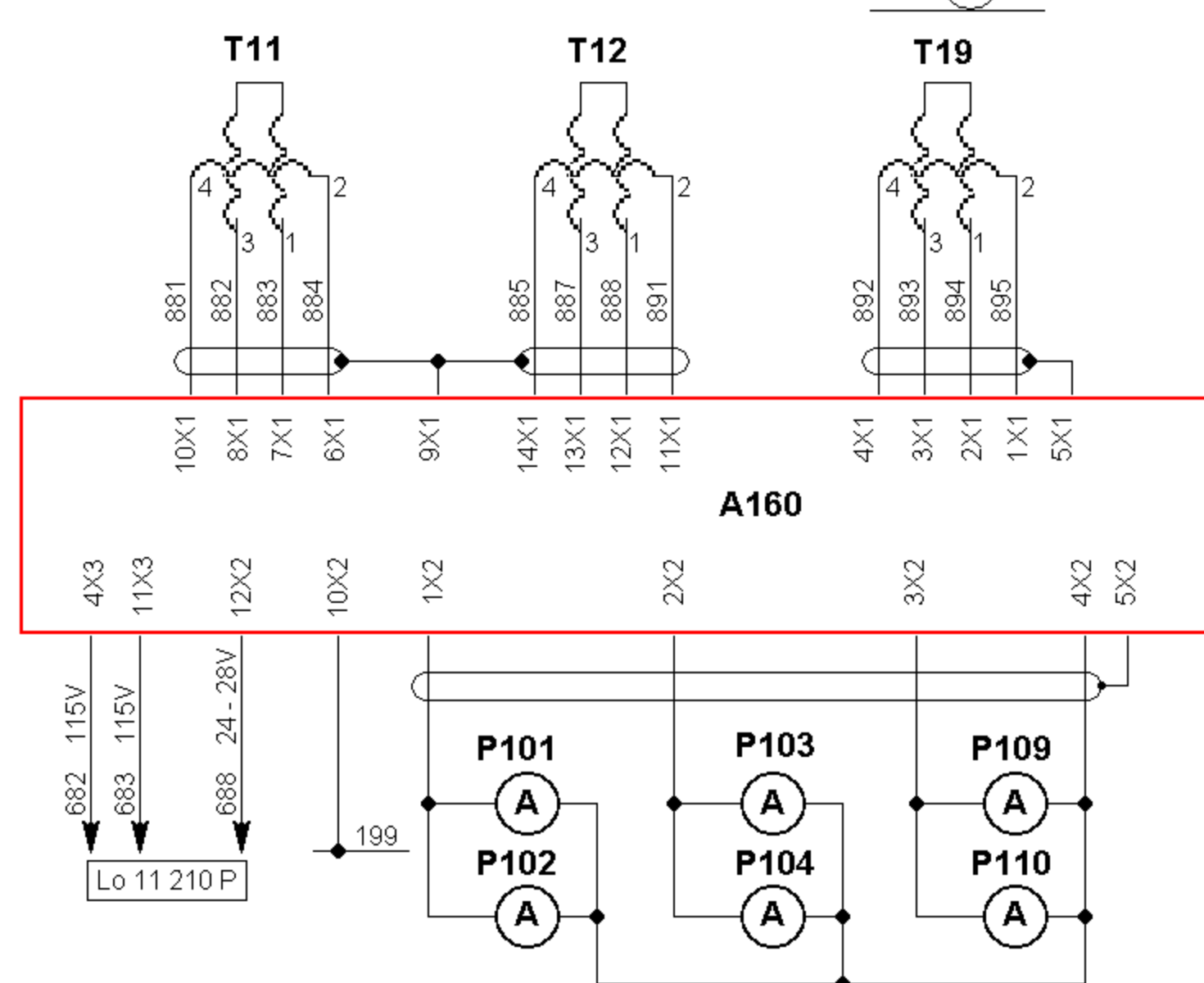
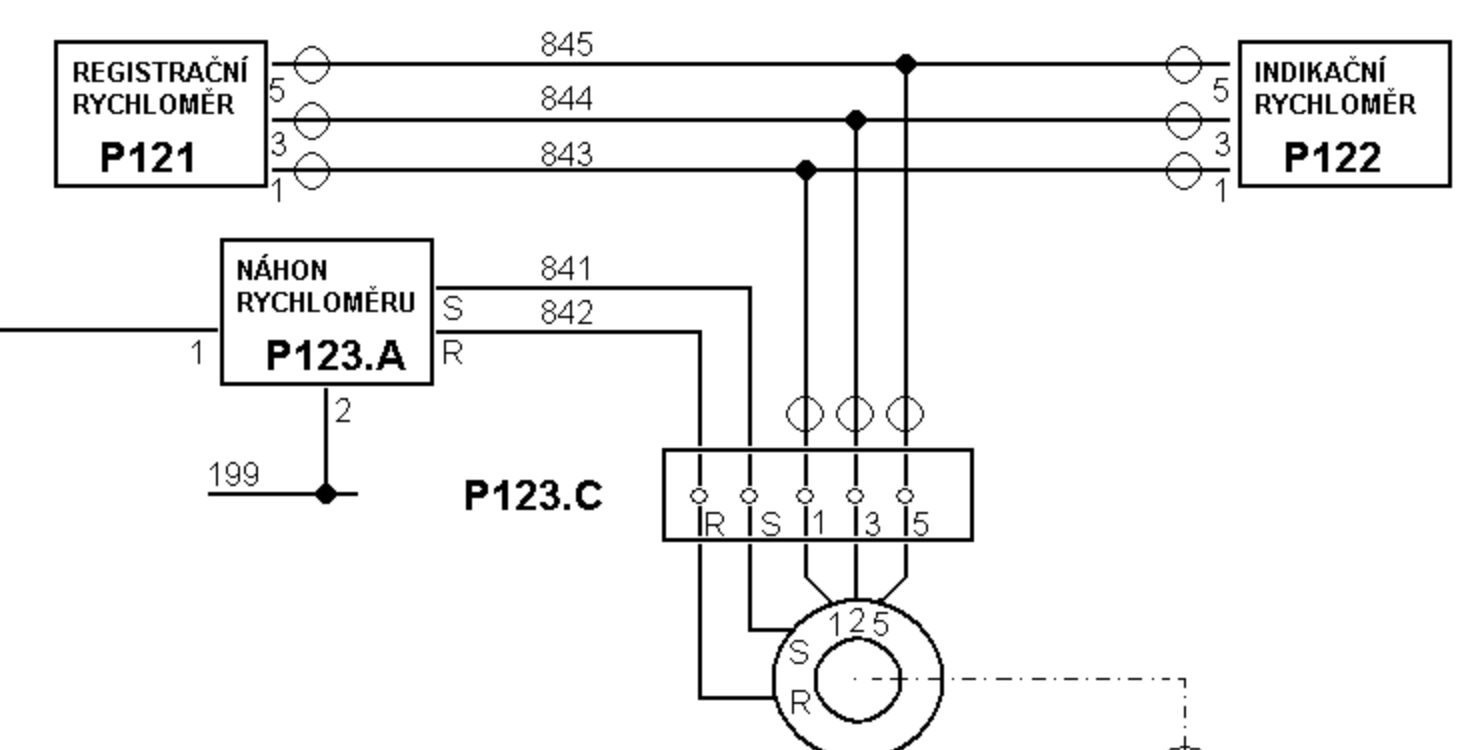
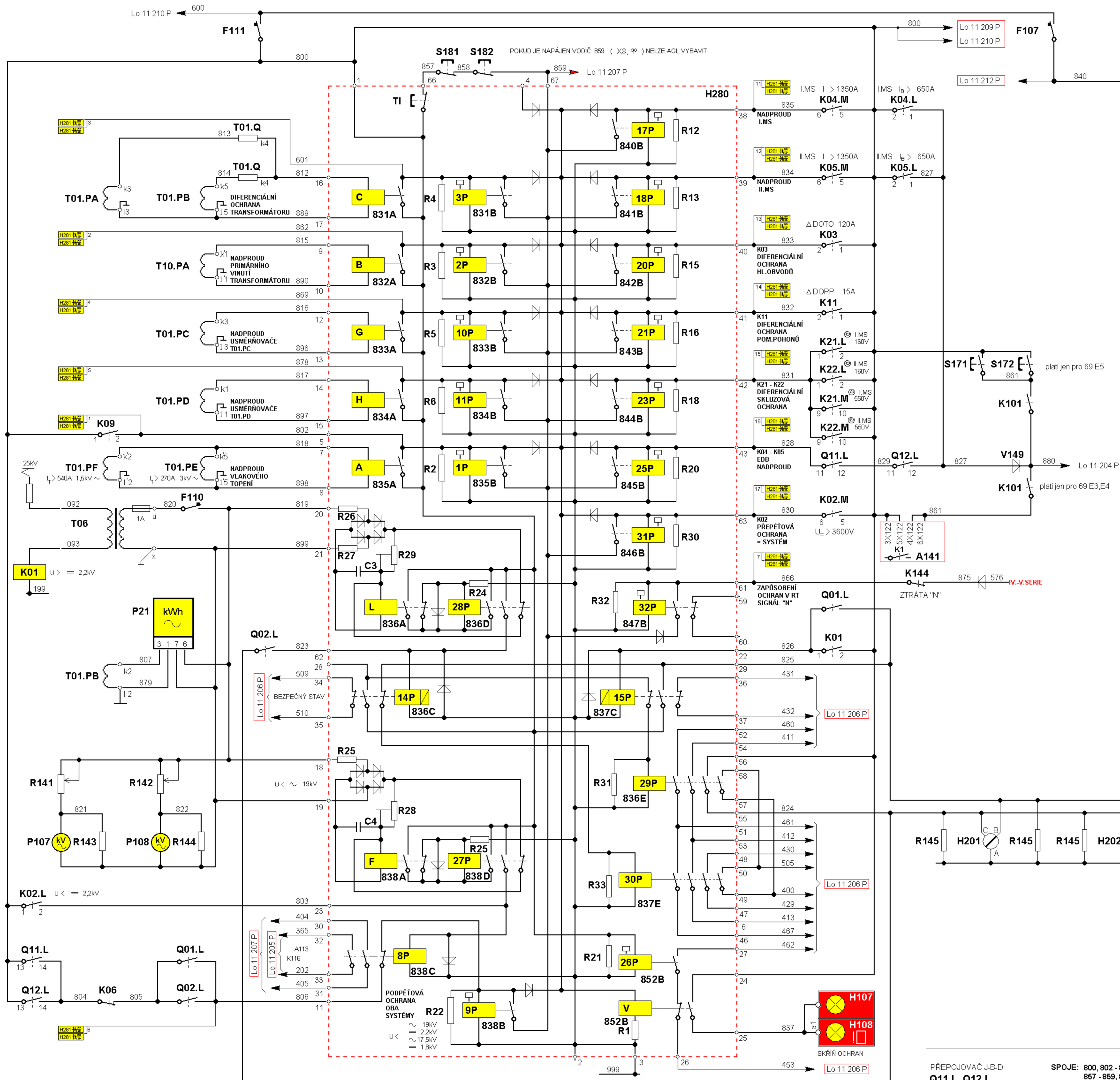

- 1P NADPROUD TOPENÍ VLAKU K09, str. T01.PF NEBO T01.PE
- 2P NADPROUD PRIMÁRU TRAFÁ; str. T01.PA
- 3P DIF. OCHRANA PRIMÁRU TRAFÁ; str. T01.PA a T01.PB
- 9P PODPĚTI str. T06, ss. K02
- 10P NADPROUD 1.MŮSTKU USMĚRNOVAČE DIUS; str. T01.PC
- 11P NADPROUD 2.MŮSTKU USMĚRNOVAČE DIUS; str. T01.PD
- 17P NADPROUD 1.MS; K04.M I_k > 1350A
- 18P NADPROUD 2.MS; K05.M I_k > 1350A
- 21P DOTO K03 dif > 120A ss.
- 23P DOPP K11 dif > 15A ss.
- 25P SKLUZ (rozdílné napětí mezi K21.M a K22.M > 180V ss.
- 26P NADPROUD EDB K04.L; K05.L I_k > 650A
- 28P NAPĚTÍ BAT.V PORÁDKU
- 31P PREPĚTÍ NA ss. SYS. K02.M > 3.8 kV
- 32P SOUČTOVÁ SIGNALIZACE

PLATÍ PRO IV.V.seri - ZOBRAZOVÁČ AGL JE NA STŘEDNÍM SLOUPKU PULTU

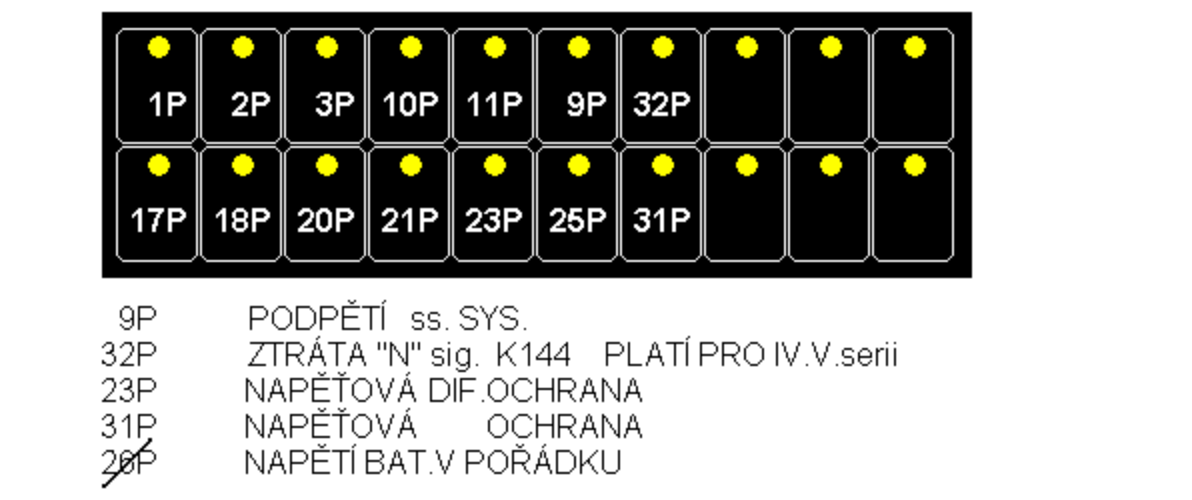

PŘEPOJOVAČ J-B-D
Q11.L, Q12.L
 J B D
 11-12
 13-14

SPOJE: 800, 802 - 807, 812 - 835, 837, 840 - 845, 857 - 859, 870 - 873, 879, 881 - 885, 880, 887 - 899

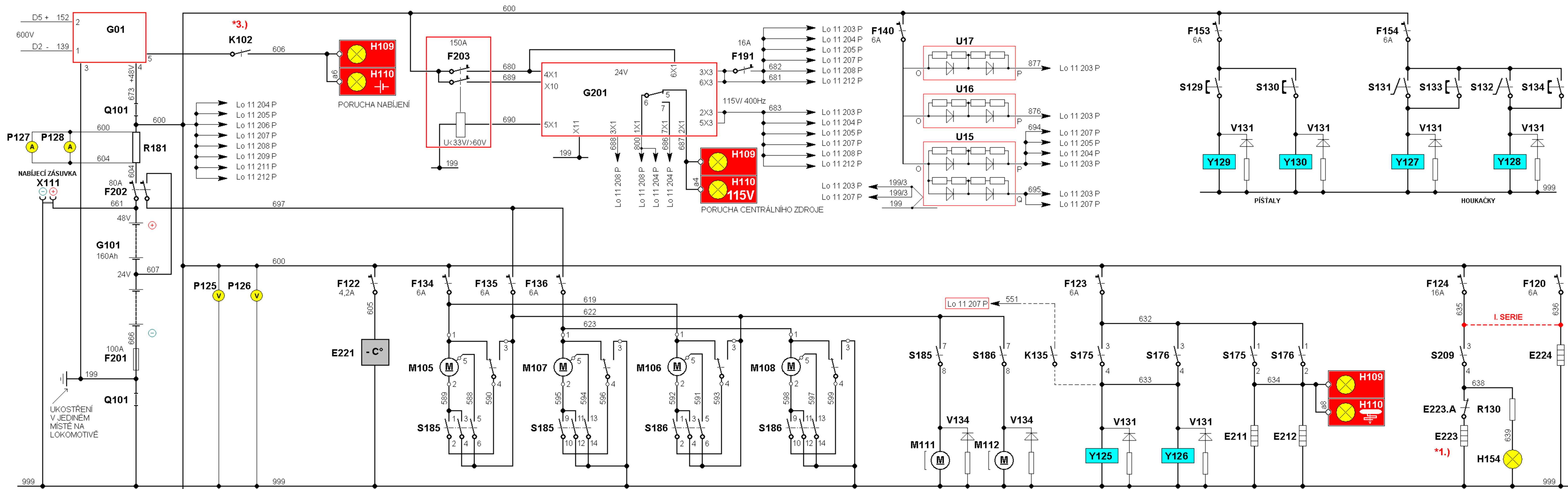

LEDNICE STĚRAČE STĚRAČE OSTRIKOVÁČE ODKALENÍ JÍMEK TOPENÍ JÍMEK OHŘÍVAČ VODY

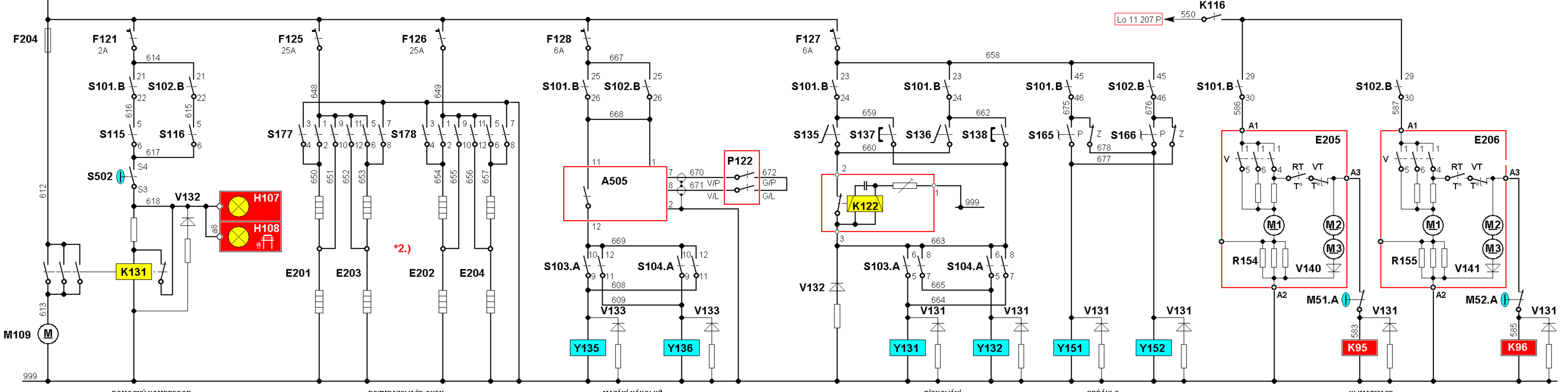

POMOCNÝ KOMPRESOR ROZMRAZOVÁČE OKEN MAZÁNÍ NÁKOLKŮ PÍSKOVÁNÍ SPRÁHLO KLIMATIZACE

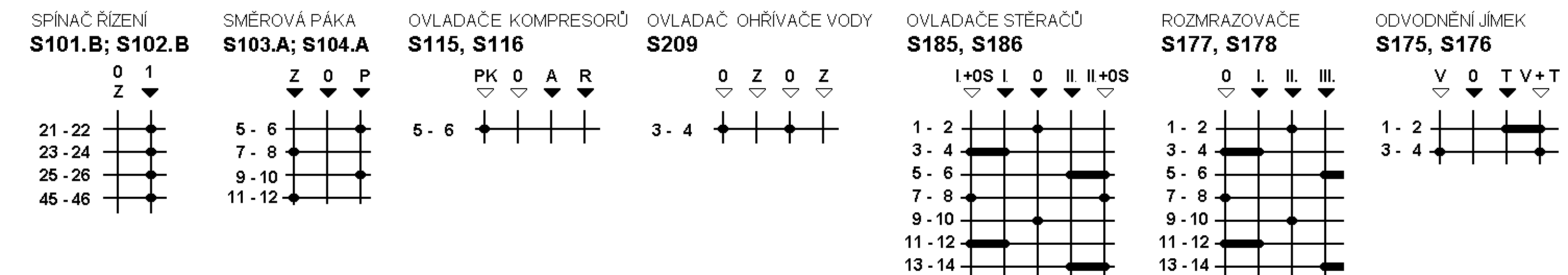

SPOJE : 582 - 599, 600, 603, 605 - 609, 612 - 619, 622, 623, 630 - 636, 638, 639, 642 - 673, 675 - 678, 680 - 683, 686 - 690, 694 - 697, 876, 877
 POTENCIÁLY VODIČŮ: 600 +48V, 199 -48V, 999 -48V, 607 +24V, 681, 682, 683 115V/400Hz

*1.) ZMĚNA V OBVODĚ E223
 *2.) U LOK. S LEPENÝMI SKLY JSOU SONDY K161 - K164 NA TEMPEROVÁNÍ PROTI OROSENÍ
 *3.) PORUCHA NABÍJEČE PŘES K102